

Signet 2751 DryLoc® pH/ORP Smart Sensor Electronics



3-2751.090 Rev. B 08/17

Operating Instructions



2751-1



2751-2



2751-3, 2751-4



- [English](#)
- [Deutsch](#)
- [Français](#)
- [Español](#)



Description

Signet 3-2751 pH/ORP Smart Sensor Electronics is a blind transmitter that processes analog signals from a pH or ORP electrode and transmits digital data via a three wire cable to a 9900 or 9950 Signet transmitter or a Signet 0486 Profibus Concentrator. The serial bus, Signet Serial Sensor Link (S³L) is the latest development in leading-edge technology from Signet.

The Signet 2751 can also output the signal over a 4 to 20 mA current loop with a pre-set scale without the expense of local display. Preamplification is built-in reducing system costs while ensuring absolute signal integrity up to 305 m (1,000 ft).

The Smart Sensor Electronics self-configure for pH or ORP via automatic recognition of electrode type. The DryLoc electrode connector quickly forms a robust assembly with the sensor for submersible and in-line installations. The Smart Sensor Electronics offers broken glass and high impedance detection, remote calibration, storage of environmental extremes, and manufacturing electrode data. (see page 10 for details).

NEMA 4X Junction Boxes are integral parts of the in-line version and are available as accessories for the submersible version.

The optional EasyCal feature allows simple push-button calibration and includes an LED for visual feedback.

Table of Contents

Warranty Information	2
Product Registration	2
Safety Information	2
Chemical Compatibility	2
Specifications	3
In-line Installation.....	4
Mounting Position	5
In-line Assembly	5
Submersible Installation	7
Digital (S ³ L) Wiring	8
4 to 20 mA Loop Wiring	8
Calibration	9
2751 Advanced Features.....	10
Troubleshooting.....	10
Parts and Accessories	11
Ordering Information.....	12

Warranty Information

Refer to your local Georg Fischer Sales office for the most current warranty statement.

All warranty and non-warranty repairs being returned must include a fully completed Service Form and goods must be returned to your local GF Sales office or distributor. Product returned without a Service Form may not be warranty replaced or repaired.

Signet products with limited shelf-life (e.g. pH, ORP, chlorine electrodes, calibration solutions; e.g. pH buffers, turbidity standards or other solutions) are warranted out of box but not warranted against any damage, due to process or application failures (e.g. high temperature, chemical poisoning, dry-out) or mishandling (e.g. broken glass, damaged membrane, freezing and/or extreme temperatures).

Product Registration







Thank you for purchasing the Signet line of Georg Fischer measurement products.

If you would like to register your product(s), you can now register online in one of the following ways:

- Visit our website www.gfsignet.com. Under **Service and Support** click on **Product Registration Form**
- If this is a pdf manual (digital copy), [click here](#)

Safety Information

1. Depressurize and vent system prior to installation or removal.
2. Confirm chemical compatibility before use.
3. Do not exceed maximum temperature/pressure specifications.
4. Wear safety goggles or faceshield during installation/service.
5. Do not alter product construction.
6. When using chemicals or solvents care should be taken and appropriate eye, face, hand, body, and/or respiratory protection should be used.

	Caution / Warning / Danger Indicates a potential hazard. Failure to follow all warnings may lead to equipment damage, injury, or death
	Personal Protective Equipment (PPE) Always utilize the most appropriate PPE during installation and service of Signet products.
	Pressurized System Warning Sensor may be under pressure, take caution to vent system prior to installation or removal. Failure to do so may result in equipment damage and/or serious injury.
	Hand Tighten Only Overtightening may permanently damage product threads and lead to failure of the retaining nut.
	Do Not Use Tools Use of tool(s) may damage product beyond repair and potentially void product warranty.
	Note / Technical Notes Highlights additional information or detailed procedure.

Chemical Compatibility

The retaining nuts of pH and ORP sensors are not designed for prolonged contact with aggressive substances.

Strong acids, caustic substances and solvents or their vapor may lead to failure of the retaining nut, ejection of the sensor and loss of the process fluid with possibly serious consequences, such as damage to equipment and serious personal injury.

Retaining nuts that may have been in contact with such substances e.g. due to leakage or spilling, must be replaced.

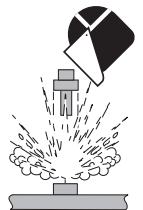

Specifications

General

Compatible Electrodes	Signet DryLoc Electrodes (PT1000 or 3K Balco temperature sensor versions for pH)
Operational Range	-1.00 to 15.00 pH, -2000 to +2000 mV ORP, 0 °C to 85 °C (32 °F to 185 °F)
Response Time (includes electrode response):	
pH	<6 s for 95% of change
ORP	application dependent
pH Temp T90	200 s (2724 and 2734) 132 s (2726 and 2736) 438 s (2756-WT)

Materials

2751-1, 2751-2 (in-line)	PBT (thermal plastic polyester), PP (retaining nut)
2751 -3, -4 (submersible)	CPVC
Cable for 2751 -3, -4 submersible versions:	
4.6 m (15 ft) 3-conductor shielded, 22 AWG	
• May be extended up to 305 m (1000 ft) with current output	
• May be extended up to 305 m (1000 ft) with (S ³ L) output	

Weight:

2751-2 (in-line)	0.75 kg
2751-1 (in-line) & 2751 -3, -4 (submersible)	0.64 kg

Environmental

Ambient Temp	0 °C to 85 °C (32 °F to 185 °F)
Storage Temp	-20 °C to 85 °C (-4 °F to 185 °F)
Relative Humidity	95% max, non-condensing
Immunity	EN50082-2
Emissions	EN50081-1
Enclosure Rating	
2751 -1, 2751 -2 (in-line)	NEMA 4X/IP65 (with electrode connected)
2751 -3, 2751 -4 (submersible)	NEMA 6P/IP68 (with electrode and watertight extension pipe connected)

Electrical

Input Impedance	>10 ¹¹ Ω
Input response time	500 ms
Temperature drift	±0.002 pH per °C, ±0.1 mV ORP per °C
Input resolution	0.02 pH, 1 mV ORP, 0.3 °C

Current output

pH	Fixed 4 to 20 mA, isolated, 0 to 14 pH (custom scaling available)
ORP	Fixed 4 to 20 mA, isolated, -1000 to +2000 mV (custom scaling available, -2000 to +2000 mV)
Power	12-24 VDC ± 10% regulated for 4 to 20 mA output
Max Loop Resistance	100 Ω max. @ 12V 400 Ω max. @ 18V 700 Ω max. @ 24V
Loop Accuracy	±32 µA @ 25 °C
Temperature drift	±1 µA per °C
Output resolution	± 5 µA
Error indication	3.6 mA, 22 mA or none
Update Rate	0.5 seconds

Digital (S³L) output:

Description	Serial ASCII, TTL level 9600 bps
Power	5 to 6.5 VDC ± 5% regulated supply, 2.5 mA max
Update Rate	0.5 seconds
Available Data	Raw mV, pH or ORP, Glass Impedance (pH), Minimum and Maximum pH, Minimum and Maximum mV (ORP), Minimum Temperature (pH), Maximum Temperature (pH), Model Number, Serial Number, Manufacturing Date, Runtime, Slope pH/mV, Measurement Offset, and Temperature Offset (pH)

System Accuracy:

pH	± 0.02 pH @ 25 °C
ORP	± 1.5 mV @ 25 °C
Temperature	0.4 °C

Resolution:

pH	≤ 0.01 pH
ORP	1.5 mV
Temperature	0.1 °C

Error indication Temp output "+999.9"

Standards and Approvals

- CE, RoHS Compliant
- Manufactured under ISO 9001 for Quality, ISO 14001 for Environmental Management and OHSAS 18001 for Occupational Health and Safety.

 China RoHS (Go to www.gfsignet.com for details)

 Declaration of Conformity according to FCC Part 15.

This device complies with Part 15 of the FCC rules.

Operation is subject to the following two conditions:

- (1) This device may not cause harmful interference, and,
- (2) This device must accept any interference received, including interference that may cause undesired operation.

In-Line Dimensions

- 2751-1 In-Line sensor (without EasyCal) is designed for applications where electrode calibration is facilitated by remote equipment.
 - A Signet installation fitting (12.7 mm to 101.6 mm [$\frac{1}{2}$ in. to 4 in.]), Wet-Tap assembly or a threaded tee is required to secure the electrode in the pipe.
- 2751-2 In-Line sensor includes EasyCal.
 - 272X, 273X, 276X and 277X series of sensors thread directly into standard 1 in or $\frac{3}{4}$ in NPT fittings.
 - The Signet Measurement and Instrumentation catalog offers a complete selection of fittings.
 - 272x and 273x series of pH and ORP electrodes are compatible with Signet Installation Fittings.
- The 2751-3 and 2751-4 submersible sensor electronics are recommended for in-line applications using the 272X, 273X, 276X and the 277x series threaded DryLoc sensors.
- 2756 and 2757 Wet-Tap sensors require the 3719 Wet-Tap assembly and can use the 2751-1 or 2751-2 versions.

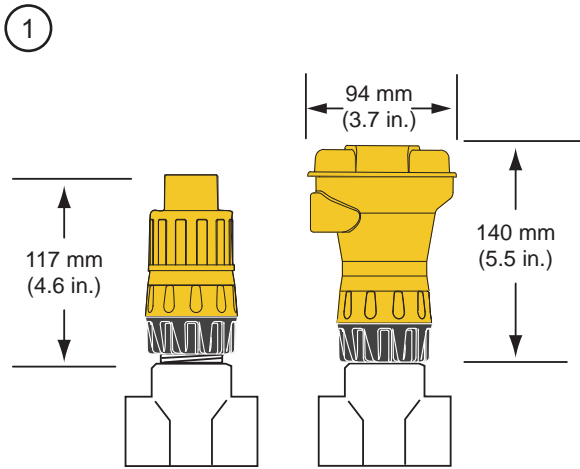

2751-1 and 2751-2 with 272X, 273X, 276X OR 277X sensors

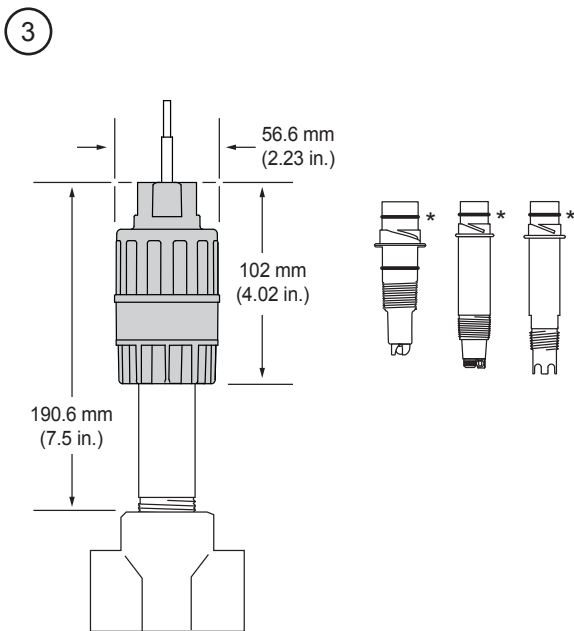
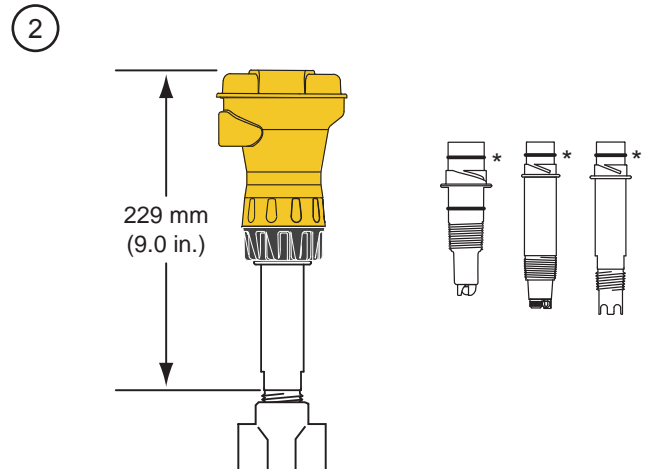

2751-3 and 2751-4 with 272X, 273X, 2764 or 2774 sensors

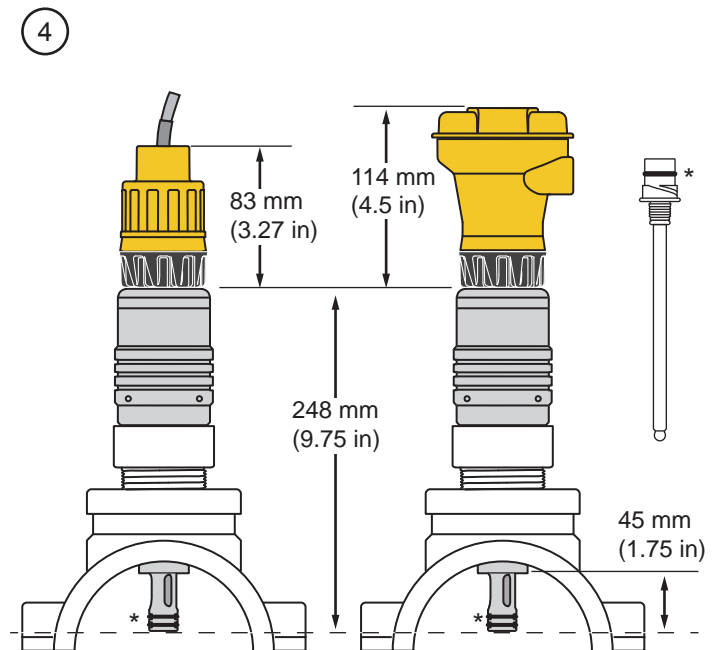

2751-1 and 2751-2 with
3719 Wet Tap and 2756 or 2757 Sensors

***NOTE:**

Lightly lubricate O-rings with a non-petroleum based, viscous lubricant (grease) compatible with the system.

Mounting Position

Wet-Tap electrodes, 2724, 2734, and 2774 series electrodes

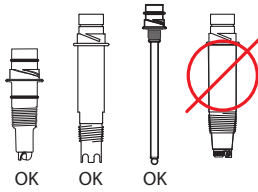

Mounting Angle using GF Signet Fittings.

*Avoid locations with air pockets and/or sediment (90° and 270°).

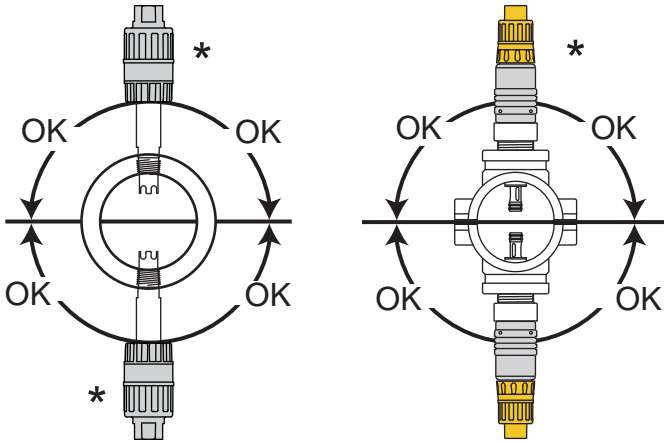

When mounting in a standard threaded fitting, the electrode must be mounted horizontal to 60 degrees below horizontal position only:

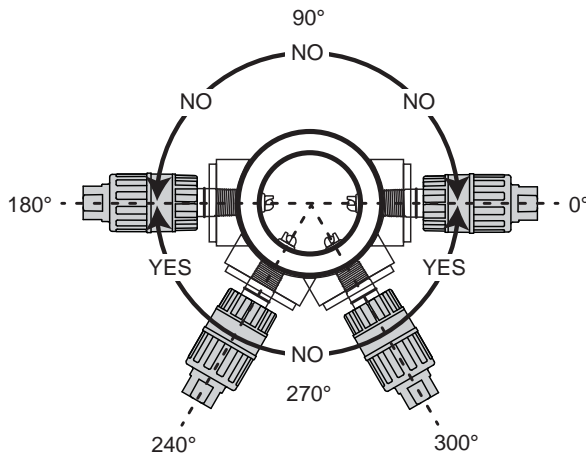

2751 In-Line pH Sensor Assembly

NOTE: This procedure applies to systems using 2724-2726 and 2734-2736 electrodes. If the 3719 pH/ORP Wet-Tap is used, refer to the 3719 manual for instructions.

1. Insert electrode into Signet installation fitting. Seat the electrode tabs into the alignment notches in the fitting.

2764 series electrodes **MUST** be mounted upright.

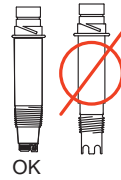

- Vertical (0°) position optimum.
- DO NOT install within 30° of horizontal (Contact factory for horizontal or inverted installation requirements).

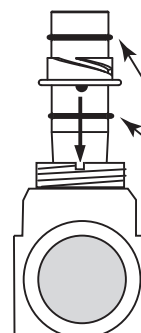
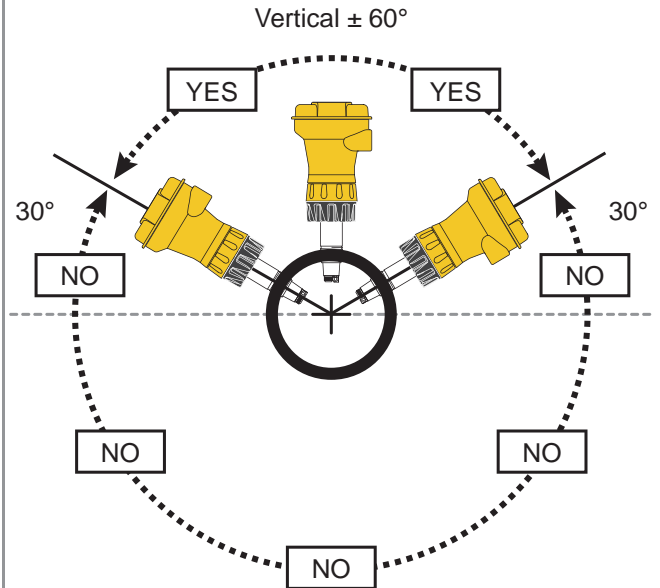

Lubricate O-rings with a non-petroleum based, viscous lubricant (grease) compatible with the system.

2751 In-Line pH Sensor Assembly - continued

- Thread the in-line retaining nut onto fitting to secure the electrode into place.



HAND-TIGHTEN THE THREADED NUT ONTO THE INSTALLATION FITTING. DO NOT USE TOOLS! DO NOT USE THREAD SEALANT OR LUBRICANTS ON THE FITTING THREADS OR THE SENSOR CAP.

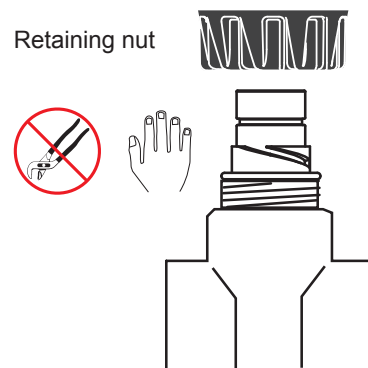

Chemical Compatibility Warning

- The retaining nuts of pH and ORP sensors are not designed for prolonged contact with aggressive substances.
- Strong acids, caustic substances and solvents or their vapor may lead to failure of the retaining nut, ejection of the sensor and loss of the process fluid with possibly serious consequences, such as damage to equipment and serious personal injury.
- Retaining nuts that may have been in contact with such substances e.g. due to leakage or spilling, must be replaced.

Note:

Keep the electrical interconnection between electrode and sensor electronics dry and clean at all times.

- Unlock the ring on base of 2751 (the ring is unlocked when the lines on the ring and body of the 2751 are not aligned.)



LUBRICATE O-RINGS WITH A NON-PETROLEUM BASED, VISCOUS LUBRICANT (GREASE) COMPATIBLE WITH THE SYSTEM.

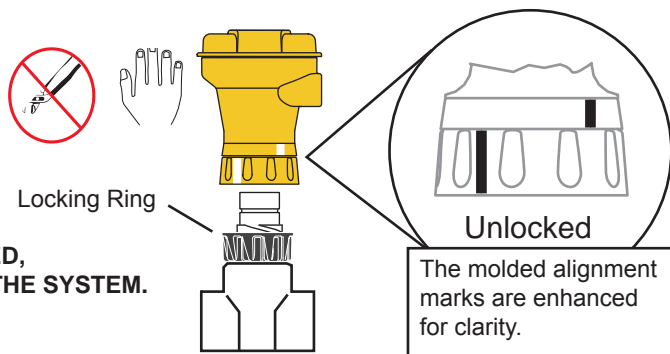

- Place 2751 onto top of electrode and turn until the assembly drops into position.

- Turn locking ring $\frac{1}{4}$ turn to secure the 2751 assembly. (The ring is locked when the line on the ring and the line on the body of the 2751 are aligned.)

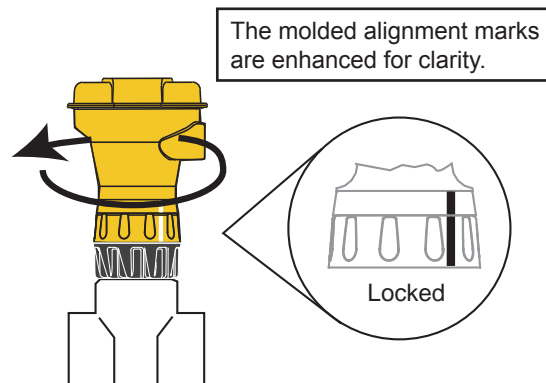

In-Line Sensor and Electrode Removal

- To remove electronics assembly only:** Turn locking ring $\frac{1}{4}$ turn; lift assembly straight up.
- To remove electrode from the pipe:** Remove electronics assembly, then unthread retaining nut; pull electrode straight up.
- To remove the complete 2751 system:** Hold locking ring in place. Unthread retaining nut and pull electrode straight up.



CAUTION!

- Do not remove the electrode from a pressurized pipe.
- Wear appropriate protective clothing when working with chemicals in pressurized pipe.

2751 -3, -4 Submersible Sensor Assembly and Installation

1. Insert electrode into base of the 2751-3 or 2751-4 and turn until keyed contacts are seated.
NOTE: Lubricate O-ring if installing sensor is difficult.
2. Thread retaining nut over electrode and hand-tighten onto 2751.
3. Attach 3/4 in. watertight pipe to the top of the 2751.
Secure the threaded connection to prevent any leakage.
 - For additional defense against possible accumulation of condensation at the back seal area of the sensor, fill the lower 75 mm to 100 mm (3 in. to 4 in.) of conduit or extension pipe with a flexible sealant such as silicone.

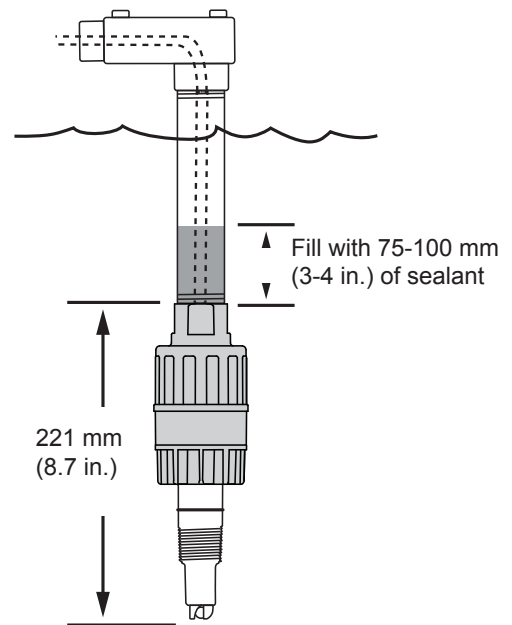
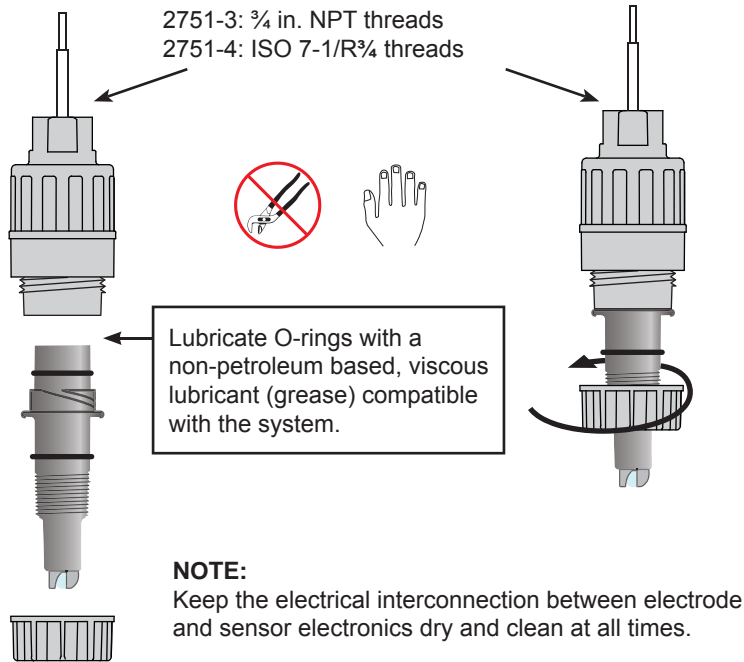

Use standard installation hardware to connect the submersible 2751 -3 or -4 directly to external equipment.

OR

The 8052-1 NPT Mount Junction box (or 8052-2 with EasyCal) connects to 3/4 in. pipe or conduit and provides convenient wiring termination.

OR

The 8050-1 Universal Mount junction box (or 8050-2 with EasyCal) mounts flat onto a wall or can be strapped to a post or pipe.

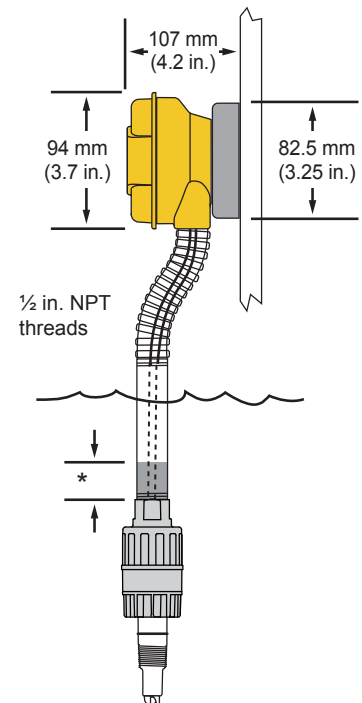
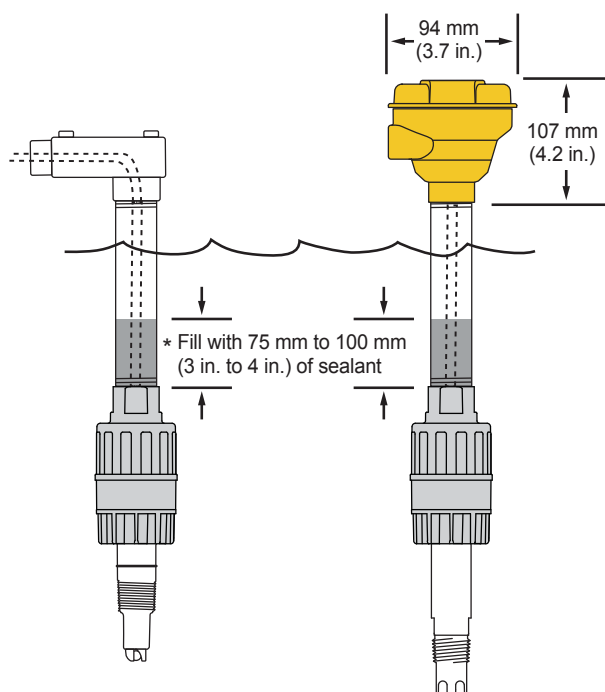

Cable supplied:

5 m (15 ft) 3-conductor + shield, 22 AWG.

- May be extended up to 305 m (1000 ft) with current output.
- May be extended up to 305 m (1000 ft) with Digital (S³L) output.

Digital (S³L) Wiring

- When the 2751 is powered with 5 VDC, the digital (S³L) serial data output is automatically selected.
- (S³L) data is used exclusively by Signet instruments.
- Remove approximately 10 mm (0.4 in.) of insulation and tin each conductor before inserting into connectors
- To add the EasyCal function the 2751-1, 2751-3 and 2751-4 use the 8050-2 or 8052-2 junction box

(S³L) with no junction box

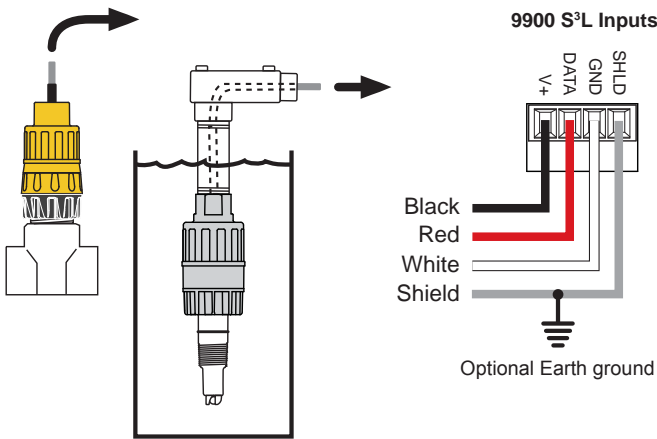

- Connect the 2751 cable directly to (S³L) I/O terminals.
- **8900 and 9900 users:**
If this direct wiring is used, set the CALIBRATE menu to perform Calibration at "INSTRUMENT"

(S³L) with junction box

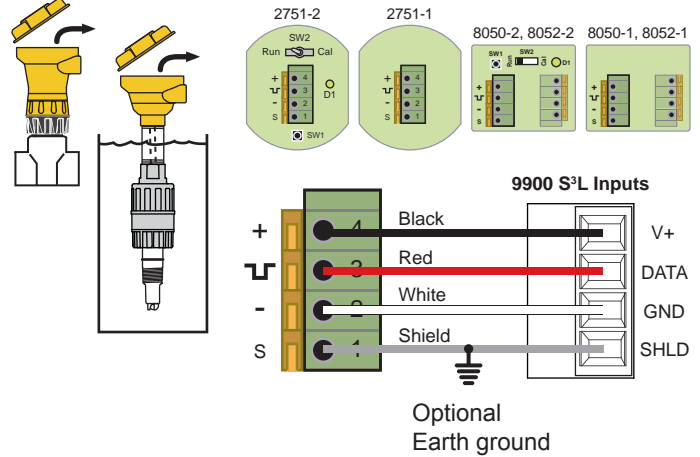

- Connect the 2751 terminals as shown to any digital (S³L) terminals.
- **8900 and 9900 users:**
If using EasyCal, set the CALIBRATE menu to either perform Calibration at "SENSOR" or "INSTRUMENT"
 - If SENSOR, use standard buffer values (pH 4, 7, or Light's Solution; ORP 264, 87, or 469 mV) to perform periodic calibration.
 - If INSTRUMENT, any pH/ORP value can be used.

4 to 20 mA Loop Wiring

- When the 2751 is powered with 12 to 24 VDC, the 4 to 20 mA loop output is automatically selected.
- Remove approximately 10 mm (0.4 in.) of insulation and tin each conductor before inserting into connectors.
- To add the EasyCal function the 2751-1, 2751-3 and 2751-4 use the 8050-2 or 8052-2 junction box

Current loop with no junction box

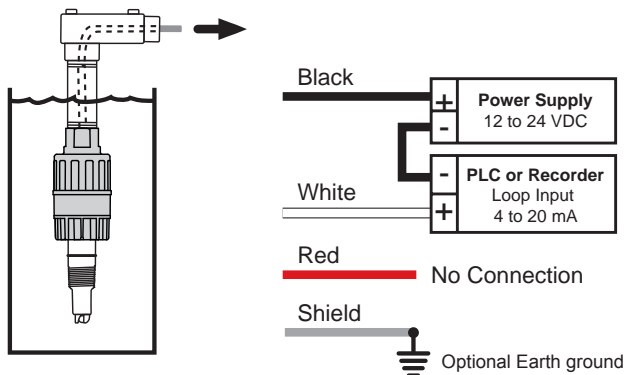

- Connect the 2751 cable directly to a Loop device as shown.
- This configuration does not provide any calibration capability within the 2751 system. Periodic calibration must be performed at the external equipment.

Current loop with junction box

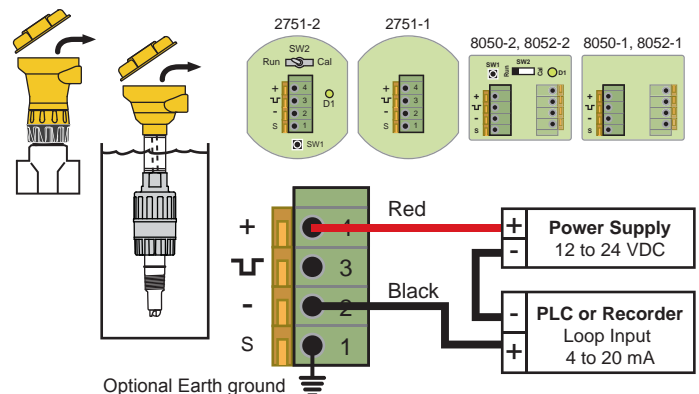

- When the 2751 includes a terminal block, connect the 2751 terminals to the Loop device as shown.
- If the 2751 includes the EasyCal accessory, use standard pH buffer values (pH 4, 7, or 10) for pH or quinhydrone saturated pH 4 or 7 or Light's solution for ORP to perform periodic calibration.

Calibration

All 2751 pH/ORP Smart Sensor Electronics are factory-calibrated for maximum out-of-the-box accuracy. Periodic recalibration is required to compensate for electrode aging.

The optional EasyCal feature allows calibration to be performed local at the sensor.

- SW1 EasyCal button
- SW2 RUN/CALIBRATE switch for (S³L) system
- D1 EasyCal Indicator (green LED)

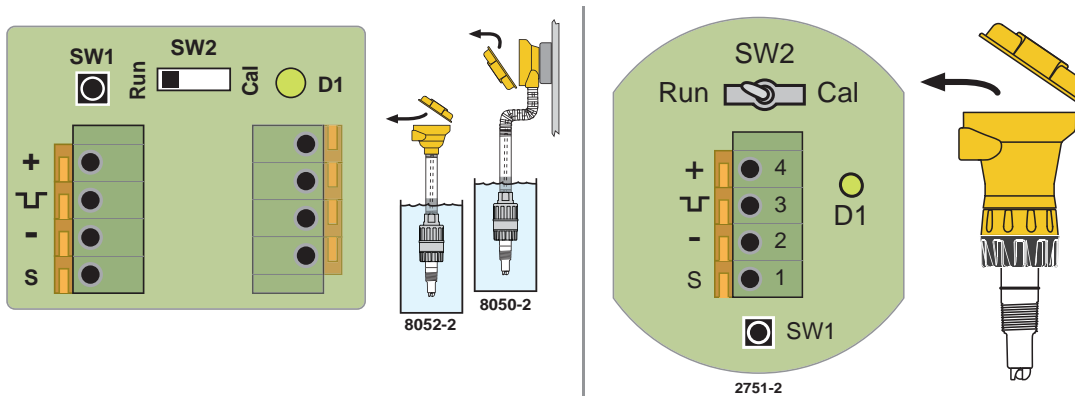

Required Equipment:

- 2751-2 with built-in EasyCal or Any 2751 with 8050-2 or 8052-2 junction box with EasyCal
- Standard pH buffers (pH 4, 7 or 10)
- Quinhydrone saturated standard pH buffers (pH 4, or pH 7) or Light's Solution, 469 mV

EasyCal Procedure:

The first step (Reset) is recommended each time an electrode is replaced, but is NOT necessary upon initial installation or periodic calibration.

In fact, for periodic calibration it is best for the electrode/sensor assembly to remain intact to minimize the possibility of moisture or other contamination entering the electrical interconnection area. The electrode/sensor connection must remain dry and clean at all times.

1. Reset the 2751 pH/ORP Smart Sensor Electronics to factory calibration: With no electrode connected to the Sensor, press and hold SW1 until the LED (D1) comes on steady then goes off again (approx. 10 seconds). When the LED goes off, one blink will occur. This indicates the reset was successful. Release SW1; reset is complete.
2. Connect an electrode to the 2751 pH/ORP Smart Sensor Electronics.
3. **If (S³L) output is being used, place SW2 in the "Cal" position. If 4 to 20 mA output is being used, SW2 position is of no consequence.**
4. Place the electrode/sensor assembly into a calibration solution as follows: (If the electrode is "healthy", then the 2751 will automatically recognize the solution. The order in which the solutions are used during the calibration procedure is of no consequence). The 2751 ORP EasyCal is a single point calibration.
 - For pH calibration, use any two of these international standards: pH 4.0, 7.0 or 10.0 buffer solutions. (Signet part number 3-0700.390 contains one capsule of each value)
 - To produce standards for ORP calibration, mix the chemical Quinhydrone into pH 7.0 and 4.0 buffers to saturation (1/8g per 50 ml). The 2751 can also use Light's Solution (469 mV), a commercial ORP calibration solution, for ORP calibration. The 2751 offers a one point ORP calibration, for this reason only a single buffer near your operating point is required for EasyCal.
 - Regardless of the size of the container used for calibration, one inch of solution is adequate to completely submerge the tip of the electrode.
 - **Allow at least 30 seconds for the electrode response to stabilize before calibration.**
5. Press and hold SW1 for approximately 8 to 10 seconds. During this time, the LED (D1) will come on steady then go back off. Release SW1 (If the LED blinks several times rapidly, the calibration was not successful. See the troubleshooting section.)
6. Remove the electrode/sensor assembly from the first calibration solution, rinse the electrode with clean water, and place it in the second solution.
NOTE: If using the 2751 Smart Sensor Electronics, only a single point is used to calibrate the 2751 and ORP electrode.
 - **Allow at least 30 seconds for the electrode response to stabilize before calibration.**
7. Press and hold SW1 for approximately 8 to 10 seconds. During this time, the LED will come on steady then go back off. Release SW1. (If the LED blinks several times rapidly, the calibration was not successful. See the troubleshooting section.)
8. **For (S³L) systems ONLY: Return SW2 to the RUN position.**

Calibration is complete. Return the system to service.

2751 Advanced Features

The Signet 2751 Smart Sensor Electronics brings new features to Signet's line of pH and ORP products.

A complete system consists of:

1. 9900 Transmitter Generation IV (or later) or 9950* Dual Channel Transmitter or 0486 Profibus Concentrator
2. 2751 Smart Sensor Electronics
3. Memory chip enabled electrode

Remote calibration of the sensors

- Calibrate the electrode in a laboratory environment and install it in the field to minimize system downtime.
- Remote calibration can be performed via one set of 2751 and 9900 Gen IV (or later) and used with another set.
- Select "Sensor Data" screen in 9900 Transmitter to complete initialization of probe at the 9900 Transmitter

On-line sensor diagnostics

- 2751 is capable of automatic measurement of the temperature compensated glass impedance (for pH only).
- In 9900 Transmitter (Gen IV or later), pH **INPUT** menu, the user can select the interval of the glass impedance measurement. Factory default is at 60 minutes.
- The glass impedance measurement takes on average 10 seconds to complete. During this time the pH monitoring is not active. The output pH is held at the pH value just prior to performing the impedance measurement. Users should perform glass impedance measurements at times when process pH is not likely to change.
- For process solutions of low conductivity, impedance measurement is not recommended. This is because the sample solution itself has high resistance which adds up to the measured impedance. Below 100 μ S, glass impedance can reach 3 times the factory glass impedance. The automatic impedance measurement function and the **HI GLASS IMPEDANCE WARNING** in this application should be set to **OFF** in the 9900 Transmitter.

Monitor pH sensor for broken pH glass

- When used with a 9900 Transmitter (Gen IV or later), 9950 Dual Channel Transmitter* or 0486 Profibus Concentrator, a **BROKEN GLASS** alarm will be displayed when pH glass impedance falls below 3 M Ω .
- Earlier versions of the 9900 (Gen I-III) and all 8900 transmitters will display a **CHECK SENSOR** warning when broken glass is detected.
- **Note:** to take full advantage of the Broken Glass alarm feature, a pH probe built after 07/2017 is needed.

Monitor sensor glass for High Impedance conditions

- High glass Impedance can be caused by chemical attack on the glass, fouling of the sensor or built up material on the glass, or if the sensor dries out.
- In the pH **INPUT** menu users can set up the **HI GLASS IMPEDANCE WARNING** to **OFF**, 3X, 4X or 5X of the factory measured glass impedance. All users should set up this condition. A setting of 3X may be appropriate. Please note that factory default is **OFF**.
- The 9900 Transmitter (Gen IV or later) will display a **HIGH IMPEDANCE** warning when the sensor impedance exceeds the value set in the pH **INPUT** menu.

Monitor Reference Impedance

- Only available for electrodes with a solution ground (Differential electrodes, 276X only).
- Values below 3 M Ω indicate a broken reference glass.
- Values above 200 M Ω indicate a severely coated or dried reference glass.

Record and display minimum and maximum process variables, and total runtime hours of sensor

- pH electrode: the memory chip will store the minimum and maximum recorded temperatures, the minimum and maximum recorded pH values and the total runtime hours of the sensor.
- ORP electrode: the memory chip will store the minimum and maximum recorded mV values and the total run time hours of the sensor.
- These values are accessible via the 9900 Transmitter (Gen IV or later), or 9950 Dual Channel Transmitters* to aid in the evaluation of environmental factors versus sensor longevity

Record and display calibration information data

- Includes: Factory calibration pH/ORP, factory calibration temperature for pH, user pH/ORP offset, user pH/ORP slope efficiency and temperature offset for pH.
- pH slope (the potential difference developed by the electrode per pH unit, $\Delta U/\Delta pH$) is displayed in percent units where 100 represents a slope of ± 59.16 mV/pH at 25° C. In practice a new electrode reaches at best 99.8% of the theoretical value.
- A new electrode should have a slope between 93.2% to 103%. As electrode ages, the slope decreases gradually.
Note: Older 9900 Gen IV instruments, units built before 11/18/15, S/N 6151118xxxx, will display slope efficiency as a decimal number instead of percent, e.g. 0.98 = 98%

Display manufacture data via the 9900 (Gen IV or later) or 9950* Transmitters

- Includes: sensor model number, serial number, and measured factory glass impedance.

2751 Blind Mode Advanced Features

2751 pH/ORP Smart Sensor Electronics can be used in blind mode (outputs the signal in 4-20 mA current loop with a pre-set scale) without the need of a local display.

Using Signet 3-0252 Configuration tool**, users can set alarm conditions using the loop output to produce optional error outputs of 3.6 mA, 22 mA or none.

- Error output conditions can be individually set, only one condition can occur at a time.
- The alarm conditions in the priority order are: 1) Missing Probe, 2) Out of Operational Range (i.e. pH range is 0 to 14 pH, ORP range: -1000 to +2000 mV), 3) Low Glass Impedance, 4) High Glass Impedance, 5) Low Reference Impedance, 5) High Reference Impedance and 6) OFF
- When more than one alarm condition exists, the state of the current loop is set by the higher priority condition. Missing probe has the highest priority (1)
- During normal operation, there is no access to the measured glass impedance, reference impedance or Sensor Data (blind).
- During operation, 2751 reads and write information in the sensor memory chip. Blind users do not have access to that information unless the 2751 is connected to a display: 9900, 9950 or Profibus Concentrator.

* Users of 9950 Gen I and 9950 (Gen 2a) should update to 9950 (Gen 2b, available in Q4) to take full advantage of the 2751 features and benefits. Visit www.gfsignet.com for the latest software update.

** Support for the advanced alarm conditions in blind mode with the 0252 Configuration Tool will be available in Q4, 2017

Troubleshooting

LED and Output Condition	Possible Causes	Suggested Solutions
Current Output: LED off, current output is 3.6 mA or 22 mA (S ³ L): Transmitter displays "Check Sensor" or "Broken Glass"	<ul style="list-style-type: none"> No electrode or damaged electrode installed. Bad/dirty contacts between electrode and 2751. 	<ul style="list-style-type: none"> Install/replace electrode. Check interconnection between electrode and 2751, clean contacts, and/or lubricate sensor o-ring.
During EasyCal, the LED blinks rapidly for 4 seconds and the current output is frozen at a fixed value.	<ul style="list-style-type: none"> The buffer solution is outside of the accepted tolerance for the 2751. The electrode is depleted (> 1.1 pH or 65 mV offset). 	<ul style="list-style-type: none"> pH system: Use fresh 4 pH, 7 pH, or 10 pH buffer and restart the calibration. ORP system: Use fresh 4 pH and 7 pH buffer solution saturated with Quinhydrone, or Light's Solution. Clean or replace the electrode.
After completing calibration procedure, the output values are inaccurate.	<ul style="list-style-type: none"> Insufficient time allowed for electrode stabilization during calibration. 	<p>Recalibrate:</p> <ul style="list-style-type: none"> Verify that test solutions are at room temperature Wait at least 30 seconds after placing electrode in solution before pressing S1 EasyCal button.
Sensor Data screen for a probe with memory chip is not available in the 9900 Gen IV	<ul style="list-style-type: none"> Error during electrode connection to the 2751 	<ul style="list-style-type: none"> Disconnect the sensor from 2751 and re-connect again
Transmitter displays the wrong Sensor Data information	<ul style="list-style-type: none"> Probe connected before 2751 acknowledged removal of the previous probe. 	<ul style="list-style-type: none"> Disconnect the probe, wait to see "CHECK SENSOR" alarm (roughly 3 seconds) prior to inserting new sensor
Transmitter displays the incorrect glass impedance after disconnecting a probe with memory chip and connecting a probe without memory chip. When removing a broken glass probe and alarm triggered, the alarm continues after new, non-memory chip electrode was installed.	<ul style="list-style-type: none"> 9900 and 2751 communication 	<ul style="list-style-type: none"> After connecting the new probe, allow 30 seconds before performing a manual glass impedance measurement. If the broken glass alarm is on, performing a manual glass impedance measurement will clear the error. Remember to allow at least 30 seconds wait time from the time the new electrode was connected.

Parts and Accessories

Mfr. Part No.	Code	Description
3-0700.390	198 864 403	pH Buffer Kit
3-2700.395	159 001 605	Calibration kit: included 3 PP cups, cup stand, 1 pint pH 4.01, 1 pint pH 7.00
3-2759	159 000 762	pH/ORP Simulator/System tester
3-2759.391	159 000 764	Adapter cable to connect 2759 and 2751
3-8050-1	159 000 753	Universal Mount Junction Box
3-8050-2	159 000 754	Universal Mount Junction Box with EasyCal
3-9900.392-1	159 000 839	Liquid tight connector kit, NPT (1 connector)
3-9900.392-2	159 000 840	Liquid tight connector kit, PG 13.5 (1 connector)
3822-7004	159 001 581	pH 4.01 buffer solution, 1 pint (473 ml) bottle
3822-7007	159 001 582	pH 7.00 buffer solution, 1 pint (473 ml) bottle
3822-7010	159 001 583	pH 10.00 buffer solution, 1 pint (473 ml) bottle
3822-7115	159 001 606	20 gram bottle Quinhydrone for ORP calibration
5523-0322	159 000 761	Cable, 3-conductor + shield (blk/red/wht/shld) 22 AWG (per ft)
P31515-0P200	159 000 630	Universal Pipe Adapter PVC
P31515-0C200	159 000 631	Universal Pipe Adapter CPVC
P31515-0V200	159 000 459	Universal Pipe Adapter PVDF
7310-1024	159 873 004	24 VDC power supply, 10W, 0.42 A
7310-2024	159 873 005	24 VDC power supply, 24W, 1.0 A
7310-4024	159 873 006	24 VDC power supply, 40W, 1.7 A
7310-6024	159 873 007	24 VDC power supply, 60W, 2.5 A
7310-7024	159 873 008	24 VDC power supply, 96W, 4.0 A
3-8050.390-1	159 001 702	Retaining Nut Replacement Kit, NPT, Valox [®]
3-8050.390-3	159 310 116	Retaining Nut Replacement Kit, NPT, PP
3-0252	159 001 808	Configuration tool
-	159 399 007	9900 pH Calibrator

Ordering Information

2751 DryLoc pH/ORP Smart Sensor Electronics

Mfr. Part No.	Code	Description
3-2751-1	159 001 804	In-line Smart Sensor Electronics with 4.6 m (15 ft) cable (recommended for use with 9900 or 9950)
3-2751-2	159 001 805	In-line Smart Sensor Electronics with Junction Box and EasyCal (recommended for current loop and 0486)
3-2751-3	159 001 806	Submersible Smart Sensor Electronics with 4.6 m (15 ft) cable, ¾ in. NPT threads
3-2751-4	159 001 807	Submersible Smart Sensor Electronics with 4.6 m (15 ft) cable, ISO 7/1-R¾ threads

DryLoc pH Electrodes

3-2724-00	159 001 547	Flat pH Electrode, DryLoc, PT1000, ¾ in. NPT or Signet fittings
3-2724-01	159 001 548	Flat pH Electrode, DryLoc, PT1000, ISO 7/1-R¾ or Signet fittings
3-2724-HF-10	159 001 771	HF Resistant, Flat pH Electrode, DryLoc, 3K Balco, ¾ in. NPT or Signet fittings
3-2724-HF-11	159 001 772	HF Resistant, Flat pH Electrode, DryLoc, 3K Balco, ISO 7/1-R¾ or Signet fittings
3-2726-00	159 001 555	Bulb pH Electrode, DryLoc, PT1000, ¾ in. NPT or Signet fittings
3-2726-01	159 001 556	Bulb pH Electrode, DryLoc, PT1000, ISO 7/1-R¾ or Signet fittings
3-2726-HF-00	159 001 551	HF Resistant, Bulb pH Electrode, DryLoc, PT1000, ¾ in. NPT or Signet fittings
3-2726-HF-01	159 001 552	HF Resistant, Bulb pH Electrode, DryLoc, PT1000, ISO 7/1-R¾ or Signet fittings
3-2726-LC-00	159 001 559	Low Conductivity, Bulb pH Electrode, DryLoc, PT1000, ¾ in. NPT or Signet fittings
3-2726-LC-01	159 001 560	Low Conductivity, Bulb pH Electrode, DryLoc, PT1000, ISO 7/1-R¾ or Signet fittings
3-2734-00	159 001 774	Flat pH Electrode + Memory Chip, DryLoc, PT1000, ¾ in. NPT or Signet fittings
3-2734-01	159 001 775	Flat pH Electrode + Memory Chip, DryLoc, PT1000, ISO 7/1-R¾ or Signet fittings
3-2734-HF-00	159 001 776	HF Resistant, Flat pH Electrode + Memory Chip, DryLoc, PT1000, ¾ in. NPT or Signet fittings
3-2734-HF-01	159 001 777	HF Resistant, Flat pH Electrode + Memory Chip, DryLoc, PT1000, ISO 7/1-R¾ or Signet fittings
3-2736-00	159 001 778	Bulb pH Electrode + Memory Chip, DryLoc, PT1000, ¾ in. NPT or Signet fittings
3-2736-01	159 001 779	Bulb pH Electrode + Memory Chip, DryLoc, PT1000, ISO 7/1-R¾ or Signet fittings
3-2736-HF-00	159 001 780	HF Resistant, Bulb pH Electrode + Memory Chip, DryLoc, PT1000, ¾ in. NPT or Signet fittings
3-2736-HF-01	159 001 781	HF Resistant, Bulb pH Electrode + Memory Chip, DryLoc, PT1000, ISO 7/1-R¾ or Signet fittings
3-2756-WT	159 000 834	Electrode, pH (glass body), DryLoc, bulb, PT1000, wet-tap
3-2756-WTP	159 001 390	Electrode, pH (plastic body), DryLoc, bulb, PT1000, wet-tap
3-2764-2	159 000 944	Differential electrode, pH, DryLoc, flat, PT1000, 1 in. NPT process connection
3-2766-2	159 000 950	Differential electrode, pH, DryLoc, bulb, PT1000, 1 in. NPT process connection
3-2774-1	159 000 956	Electrode, pH, DryLoc, flat, PT1000, ¾ in. NPT process connection
3-2776-1	159 000 960	Electrode, pH, DryLoc, bulb, PT1000, ¾ in. NPT process connection

DryLoc ORP (Redox) Electrodes

3-2725-60	159 001 561	Flat ORP Electrode, DryLoc, 10KΩ ID, ¾ in. NPT or Signet fittings
3-2725-61	159 001 562	Flat ORP Electrode, DryLoc, 10KΩ ID, ISO 7/1-R¾ or Signet fittings
3-2735-60	159 001 782	Flat ORP Electrode, DryLoc, 10KΩ ID, ¾ in. NPT or Signet fittings
3-2735-61	159 001 783	Flat ORP Electrode, DryLoc, 10KΩ ID, ISO 7/1-R¾ or Signet fittings
3-2757-WT	159 000 835	Electrode, ORP (glass body), DryLoc, bulb, 10KΩ ID, Wet-Tap
3-2757-WTP	159 001 391	Electrode, ORP (plastic body), DryLoc, bulb, 10KΩ ID, Wet-Tap
3-2765-1	159 000 946	Differential electrode, ORP, DryLoc, flat, 10KΩ ID, 1 in. NPT process connection
3-2767-1	159 000 952	Differential electrode, ORP, DryLoc, bulb, 10KΩ ID, 1 in. NPT process connection
3-2775	159 000 957	Electrode, ORP, DryLoc, flat, 10KΩ ID, ¾ in. NPT process connection
3-2777	159 000 961	Electrode, ORP, DryLoc, bulb, 10 KΩ ID, ¾ in. NPT process connection



Georg Fischer Signet LLC, 3401 Aero Jet Avenue, El Monte, CA 91731-2882 U.S.A. • Tel. (626) 571-2770 • Fax (626) 573-2057
For Worldwide Sales and Service, visit our website: www.gfsignet.com • Or call (in the U.S.): (800) 854-4090
For the most up-to-date information, please refer to our website at www.gfsignet.com