DRAMM **AUTOFOG™**



MLVH-10A **Owners Manual**

Table of Contents

Warranty	4
Warning	5
How Does My Autofog Work?	7
Assembly Instructions	8
Pre-Operation Checklist.....	8
Chemical Mixture and Application	9
Low Rate Calculations	10
High Rate Calculations.....	11
Spraying Procedure/Timer Settings	12
Cleaning & Maintenance.....	13
Assembly Diagram	14
Assembly Parts List.....	15
Compressor Plumbing Diagram	16
Compressor Plumbing Parts List.....	17
Compressor Diagram	18
Compressor Parts List.....	19
Nozzle Assembly Parts List.....	20
Troubleshooting.....	21-22
Notes	23

AUTOFOG™

MLVH-10A

CONGRATULATIONS! You have just purchased a technologically advanced Dramm Autofog which will allow you to apply chemicals automatically, efficiently, and safely– without a human operator.

Model: MLVH-10A
120 Volt 60 HZ
11.2 AMP Single-Phase

Nozzle Serial Number

Compressor Serial Number

Agitator Serial Number

Shipped To:

Test Run & Final Inspection

_____ minutes to spray

_____ cubic centimeters of clear water

_____ passed final inspection

By: _____

Date: _____

Limited Warranty

Dramm Corporation warrants, to the extent of the purchase price, that the Autofog MLVH-10A will be free from defects in materials and workmanship to the original purchaser for a period of six months. The nozzle O-ring, compressor air filters, chemical line, air line, pressure gauges and parts subject to wear are not covered under this limited warranty. Defects or damages due to the misuse, non-observance of safety standards, or non-observance of EPA pesticide guidelines are not covered under this limited warranty. Please read and follow the instructions and heed warnings stated in the operating manual and on the Autofog unit.

The Dramm Corporation makes no other further warranty, expressed or implied, and all other or further warranties, including any warranties of merchantability or fitness for a particular purpose are expressly excluded.

In no event shall the Dramm Corporation be liable for loss of product, profit or any other special, incidental or consequential damages including, but not limited to, plant damage, property or persons.

This warranty begins on the date of original purchase. If warranty service is required, the equipment must be sent prepaid to:

Autofog Service
c/o Dramm Corporation
2000 North 18th Street
Manitowoc, WI 54220

The Dramm Corporation makes no warranty, express or implied, in regard to the efficacy of any pesticide or other chemical which may be applied using the Autofog MLVH-10A.

WARNING

The Dramm Mini Autofog MLVH-10A sprays dangerous toxic chemicals. Please read and understand the following safety precautions before operating your Autofog. Failure to follow these instructions may result in serious injury or death.

- The Dramm Autofog MLVH-10A is a low-volume application machine that applies **Hazardous Chemicals** in concentrated solutions. **Care** and **Logic** must be adhered to. The solution particle size is very small (0.5 microns to 10.0 microns). **Beware of inhalation.**
- **Follow EPA Guidelines** for application of chemicals.
- **Wear Protective Clothing**, gas mask, hood gloves and boots when mixing chemicals, pouring chemicals into the tank and when applying chemicals.
- **Ensure area to be treated is securely closed** - with no vents open.
- **Ensure That No humans or Pets Are In The Area To Be Treated** - death from chemicals could occur!
- After the machine has been turned on, chemical application begins. Exit the area immediately. Secure or lock the enclosure. Post "**Do Not Enter**" hazard signs. **The Deadly Chemical Vapor Will Not be Visible!** It is your responsibility to ensure no one can enter the enclosure for at least 6 hours after the machine has stopped applying chemical.
- **Before Re-Entry, Air Must Be Changed By Venting.** Follow all EPA Guidelines for re-entry periods.
- **Do Not Use This Machine In An Enclosure Where Vapors Can Enter Any Type Of Air Vents.** Care should be taken to ensure vapors can not reach buildings or homes in close proximity to the enclosure being treated.
- **After Use, Double Rinse The Chemical Tank** and dispose of rinse water according to EPA Guidelines. Clean the nozzle and suction line thoroughly. Store the unit in a safe location away from children and unauthorized personnel.
- **Mix Only The Amount of Chemical Which Will Be Used** to treat the area. **Never - Keep - Store - Or Hold Over Unused Chemical Solution.**
- Your machine is labeled 110 volt - single phase, 220 volt - single phase or 220 volt - 3 phase. **Be Sure To Connect Your Machine To The Correct Voltage Receptacle.** Contact your electrician for accurate voltage/phase readings if necessary.
- **Exercise Accepted Safety Procedures** when using electricity.

Autofog MLVH-10A Assembly Instructions

List of tools needed:

- **7/16" Wrench**
 - **1/2" Open End Wrench**
 - **9/16" Open End Wrench**
 - **Straight Blade Screwdriver**
 - **MLVH-10A Assembly Diagram**
 - **1/2" Socket Wrench**
1. Attach handle to side of machine opposite control panel using four 1/4- 20 x 3/4 hex bolts. Tighten.
 2. Place lower nozzle stand over studs showing through red compressor unit cover. Adjusting knob should face control panel. Place lockwashers and nuts on studs and tighten.
 3. Insert the nozzle stand into the nozzle stand tube with the nozzle bracket facing away from the control panel end. Adjust the height of the nozzle stand as necessary. Tighten the black height adjustment knob.
 4. Place the solution tank into the circular tank holder. Rotate the tank so that the small suction hole faces the front of the machine (the control panel end is the back of the machine).

5. Secure the nozzle onto the nozzle stand. Insert the suction tube into the solution tank. Check that the suction tube reaches the bottom of the tank (there is a slight depression in the bottom of the tank where the suction tube should rest). Place the agitator back into the solution tank and secure with the turn tabs.
6. On the control panel, insert air hose into the press-fit connection marked AIR TO NOZZLE. On the nozzle, insert air hose the same way.
7. Plug the agitator power cord into the control panel and connect the main power cord into a 110 volt power source.
8. The unit is ready to spray. But before you start spraying, read this manual thoroughly and follow all E.P.A. Guidelines.
9. Before you spray for the first time, test the MLVH-10A with water. Pour a small amount of clear water (about 1 liter) into the solution tank. Rotate the timer clockwise. Spraying begins immediately. Observe the quality of the spray pattern and pressure gauge readings. If you have any questions, contact the Dramm Corporation Service Department at 800-258-0848 or 920-684-0227.

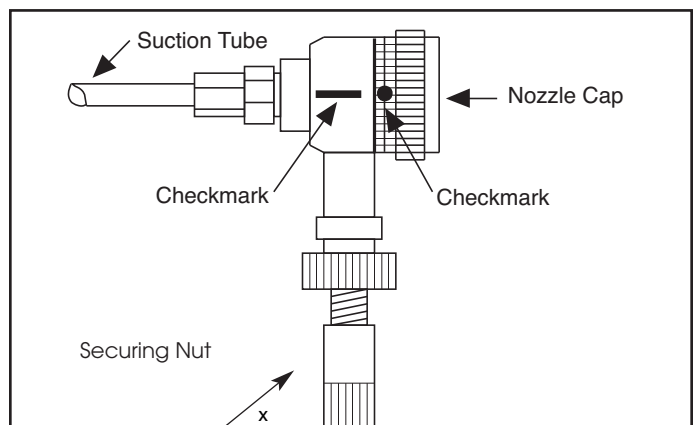
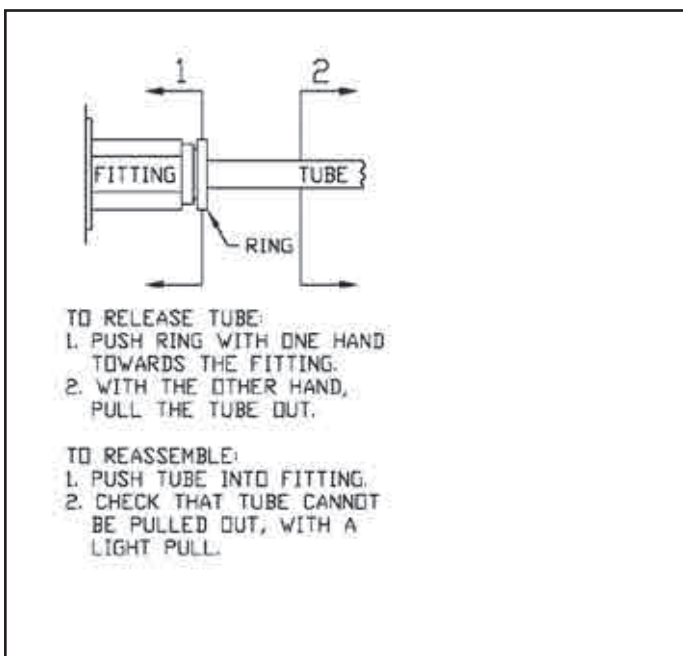

Note: Dramm offers an instructional video on our website. Please watch this before using your machine.

How Does My Autofog MLVH-10A Work?

The Dramm Autofog applies chemicals under the low-volume (LV) principle. This means that the same amount of active chemical is applied to a given area, but the chemical is diluted into reduced amounts of water. Because LV application is very efficient, many users have found that lower volumes of chemical can be used with the same results.

The Mini Autofog MLVH-10A will require a minimum of 2 liters of water and the chemical to treat 5,000 square feet. If less than 5,000 square feet is treated, a minimum of 2 liters of water is still used. The specially designed solution tank and agitator prevents concentrated chemicals from precipitating. According to conventional high-volume (HV) spraying methods, approximately 20 gallons of water (diluent) plus the chemical is needed to treat 5,000 square feet.

LV application is only possible when extremely fine particles are produced. The patented nozzle design of the Mini Autofog MLVH-10A produces particles which will range in size from .5 to 10 microns in diameter. Air enters the nozzle from the oil-less compressor and then exits the nozzle at super sonic speeds. This movement of air creates a venturi that draws solution from the chemical tank. As the solution exits the nozzle it is micronized into billions of tiny particles. The micronized chemical particles stay suspended for up to 6 hours and are distributed by horizontal airflow fans (HAF) and natural air currents.

The Mini Autofog MLVH-10A features manual starting and a timer for automatic shut-down. Other features include a safety valve on the compressor to release any abnormal pressure build-up. The motor which drives the compressor is supplied with a grounded electrical cord set and is protected from overheating with a thermal fuse that disconnects power to the entire sprayer. The Mini Autofog MLVH-10A now has a redesigned frame and handle to ease in its transportation in small greenhouses and storage facilities.



Precautions / Pre-Operation Checklist

Treatment Area

- A. For the most effective performance, the treatment area must be air tight. Take time to repair any broken glass, torn poly and gaps or openings in vents and door frames.
- B. The entire treatment area should be vacant. No humans or pets should be present.
- C. It is recommended that the application process take place at the end of the day. Secure the treatment area and post hazard signs *before* spraying.
- D. Avoid spraying when the temperature is over 85°F in the treatment area or when relative humidity exceeds 85%.
- E. When utilizing horizontal airflow fans (HAF), run them for 1/2 hour longer than actual spraying time.
- F. Follow all EPA Guidelines regarding the application of chemicals.
- D. Cold weather operation: When the temperature falls below 32°F run the compressor in a warm environment before placing the MLVH-10A assembly in the area to be treated. The bearing grease may harden in very cold temperatures causing the compressor to not perform properly. Unless absolutely necessary, do not operate the MLVH-10A in sub 25°F weather.
- E. **You will get an accurate output volume if the nozzle cap is closed completely and then returned to match the red check marks. See diagram below.**

NOTE:

Output volume will vary 2.5 - 3.0 cc/min. for each notch in the nozzle cap.

- Clockwise: Output INCREASES
- Counterclockwise: Output DECREASES

NOTE:

Check the O-ring located inside the nozzle cap for wear or damage. Replace if necessary

Compressor/Sprayer

- A. Test run the MLVH-10A with clear water for 1-2 minutes. Observe the spray quality.
- B. The discharge volume rate of clean water is approximately 45 cc / minute. When testing the unit, pull the suction hose out of the solution tank and place it in a graduated cylinder (fill it with 90 cc of clean water). The cylinder should be empty after a 2 minute test run. Be sure to check the discharge volume rate regularly to assure best results.
- C. Observe the operating pressure. The gauge will read 14-23 PSI. **NOTE:** Check for leaks in the piping when the pressure is too low. Eliminate clogs if the pressure is too high. Pressure readings may vary from location to location. Small differences are inconsequential.

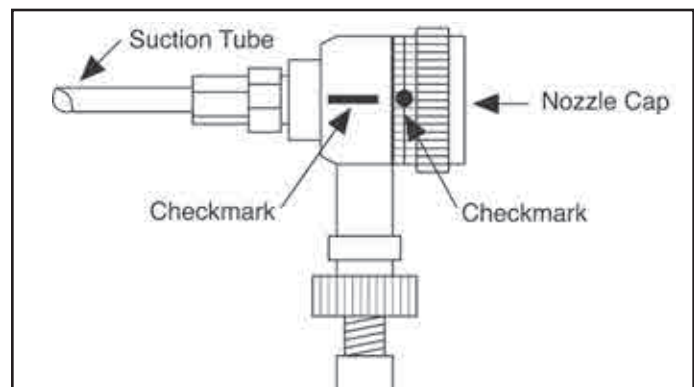

WARNING: The standard model Autofog uses a nozzle that is manufactured with brass components. The use of oxidizers will damage this nozzle within several applications.

If you plan to use oxidizers in your Autofog, **CONTACT DRAMM BEFORE THE FIRST USE OF YOUR MACHINE** to purchase a stainless steel nozzle at a reduced cost. After your machine has been used, Dramm cannot accept the original nozzle back for credit.

Preparation of Chemical Mixture and Application

1. Determine the treatment area size in square feet.

NOTE:

A minimum of 2 liters of water should be added to the active chemical when treating less than 5,000 square feet. More water should be added to dilute larger volumes of chemical (to a 15 to 1 ratio).

2. Calculate the chemical amount.

Example: Labeled chemical rate per 100 gallons is 16 ounces. We will first calculate a rate for 10,000 square feet.

Low Rate: $16\text{oz.} \times 0.20 = 3.2\text{oz.}$
(for 10,000 square feet)

High Rate: $16\text{oz.} \times 0.35 = 5.6\text{oz.}$
(for 10,000 square feet)

NOTE:

Divide the rate per 10,000 square feet by 2 for the rate per 5,000 square feet. If you are treating areas less than 5,000 square feet, make the rate calculation for 5,000 square feet and reduce that amount proportionately. Contact the Dramm Service Department at 800-258-0848 or 920-684-0227 if you have any questions.

3. Calculate the water volume for at least a 15 to 1 ratio for wettable powder and flowable formulations. Mix water with chemical in the mixing pitcher. Pour the mixture into the solution tank through the strainer. Eliminate dirt and globs of chemical that may clog the nozzle. When using wettable powders, make a lump-free slurry of the powder to wet it completely and then add the remaining portion of water. For ECs use a 10:1 dilution ratio.
4. Position the MLVH-10A for spraying.
5. Install the solution tank on the sprayer and insert the nozzle suction tube. Make sure the suction tube reaches the bottom of the tank. When a full chemical tank is loaded onto the MLVH-10A, do not move the machine to avoid spilling the chemical solution.

6. Connect the MLVH-10A to a 120V 60HZ power source and set the timer by rotating past and then returned to the desired spraying time. **The spraying process begins immediately – vacate the treatment area.**

NOTE:

Always wear protective clothing, gas mask, hood, gloves and boots when mixing chemicals and using the MLVH-10A.

Application of Chemicals

1. **WARNING:** All EPA Guidelines on the handling, application and re-entry periods for chemicals must be adhered to. Only crops which are listed on the chemical label should be treated.
2. Labeled chemical rates are stated in amounts of chemical to be diluted into 100 gallons of water. Most chemical labels *do not* advise how much of the spray concentrate should be applied to a given area.
3. Greenhouse growers apply from 25 to 300 gallons of spray concentrate per 10,000 square feet, the average high volume application is 40 - 50 gallons per 10,000 square feet.
4. The MLVH-10A is a low-volume applicator. Low volume means application of chemical in a very concentrated solution. The same amount of chemical is applied to a given area as conventional spraying, but in greatly reduced quantities of water. This is possible since low volume equipment produces very small particle sizes (0.5 to 10.0 microns) versus conventional spray particles of 100 to 400 microns.
5. If you would normally spray 25 gallons of solution into 10,000 square feet of area you are applying 25% of the chemical mixed in 100 gallons of water. (Per labeled rate per 100 gallons).
6. The charts starting on the following page will help you calculate the proper chemical amounts and water volumes.

LOW RATE

If you spray 25 gallons per 10,000 square feet you will need...

CHEMICAL LABELED RATE PER 100 GALLONS		LOW RATE MULTIPLIER .20		CHEMICAL REQUIRED IN 10,000 SQ.FT.
16 oz	X	.20	=	3.2 oz
12 oz	X	.20	=	2.4 oz

The following chart carries out the multiplication for you and reduces the chemical by 5% to compensate for run-off.

CHEMICAL LABELED RATE PER 100 GALLONS		RATE FOR 10,000 SQUARE FEET		RATE FOR 5,000 SQUARE FEET	MINIMUM AMOUNT OF WATER FOR 5,000 SQ. FT.		
					E.C.	W.P. OR F	
4 oz X .20	=	0.8 oz	÷ 2	=	0.4 oz	2 liters	3 liters
6 oz X .20	=	1.2 oz	÷ 2	=	0.6 oz	2 liters	3 liters
8 oz X .20	=	1.6 oz	÷ 2	=	0.8 oz	2 liters	3 liters
10 oz X .20	=	2.0 oz	÷ 2	=	1.0 oz	2 liters	3 liters
12 oz X .20	=	2.4 oz	÷ 2	=	1.2 oz	3 liters	4 liters
14 oz X .20	=	2.8 oz	÷ 2	=	1.4 oz	3 liters	4 liters
16 oz X .20	=	3.2 oz	÷ 2	=	1.6 oz	3 liters	4 liters
18 oz X .20	=	3.6 oz	÷ 2	=	1.8 oz	3 liters	4 liters
20 oz X .20	=	4.0 oz	÷ 2	=	2.0 oz	3 liters	4 liters

Note: 1 Liter = 33.6 Ounces. We do not recommend concentrations stronger than a ratio of 15 to 1 for Wettable Powders and Flowables. A ratio of 10 to 1 for Emulsifiable Concentrates.

Note: New chemicals or chemicals which have been re-labeled may recommend how many ounces should be applied per acre. If this is a chemical you intend to use, the labeled rate should be followed.

E.C. = Emulsifiable Concentrate

F. = Flowable

W.P. = Wettable Powder

Make Your LOW RATE Calculations Below.

HIGH RATE

If you spray 40 gallons per 10,000 square feet you will need...

CHEMICAL LABELED RATE PER 100 GALLONS		HIGH RATE MULTIPLIER .35	=	CHEMICAL REQUIRED IN 10,000 Sq.Ft.
16 oz	X	.35	=	6.4 oz
12 oz	X	.35	=	4.8 oz

The following chart carries out the multiplication for you and reduces the chemical by 5% to compensate for run-off.

CHEMICAL LABELED RATE PER 100 GALLONS	=	RATE FOR 10,000 SQUARE FEET	÷ 2	=	RATE FOR 5,000 SQUARE FEET	MINIMUM AMOUNT OF WATER FOR 5,000 Sq. Ft.	
						E.C.	W.P. OR F
4 oz X .35	=	1.4 oz	÷ 2	=	0.7 oz	2 liters	3 liters
6 oz X .35	=	2.1 oz	÷ 2	=	1.0 oz	2 liters	3 liters
8 oz X .35	=	2.8 oz	÷ 2	=	1.4 oz	3 liters	4 liters
10 oz X .35	=	3.5 oz	÷ 2	=	1.7 oz	3 liters	4 liters
12 oz X .35	=	4.2 oz	÷ 2	=	2.1 oz	3 liters	4 liters
14 oz X .35	=	4.9 oz	÷ 2	=	2.4 oz	4 liters	5 liters
16 oz X .35	=	5.6 oz	÷ 2	=	2.8 oz	4 liters	5 liters
18 oz X .35	=	6.3 oz	÷ 2	=	3.1 oz	4 liters	5 liters
20 oz X .35	=	7.0 oz	÷ 2	=	3.5 oz	4 liters	5 liters

Note: 1 Liter = 33.6 Ounces. We do not recommend concentrations stronger than a ratio of 15 to 1 for Wettable Powders and Flowables. A ratio of 10 to 1 for Emulsifiable Concentrates.

Note: New chemicals or chemicals which have been re-labeled may recommend how many ounces should be applied per acre. If this is a chemical you intend to use, the labeled rate should be followed.

E.C. = Emulsifiable Concentrate

F. = Flowable

W.P. = Wettable Powder

Make Your HIGH RATE Calculations Below.

Spraying Procedure

1. Vacate the treatment area, secure all entry ways and post hazard signs.
2. Prepare the chemical solution. See page 10 for dilution rate details. Be sure that the solution is free of clumps of chemical that may clog the nozzle. Use a whisk or blender to make a smooth paste of wettable powder solutions. Check that the suction tube screen is in place in the tank. Pour the solution through the large solution strainer/ funnel assembly to eliminate any unmixed chemical or debris.
3. Plug in the main power cord. Notice the power lamp illuminated on the control panel.
4. Set the timer. Turn the dial past, then return to the desired operation time. The MLVH-10A will begin to spray, vacate the treatment area immediately.
5. If horizontal airflow fans are used, allow them to run a half hour longer than the predetermined spray time.
6. In order to allow all of the spray particles to settle, do not re-enter the treatment area for a minimum of 6 hours after the MLVH-10A has completed its operation. Keep the structure airtight. However, if it is necessary to enter the treatment area during application, only do so in a full spray suit, boots, gloves, hood and respirator.
7. After spraying, ventilate the treatment area with fresh air and clean the MLVH-10A thoroughly. Follow all EPA Guidelines for re-entry.

DISCHARGE TIMES FOR MLVH-10A

Clear Water	Time
1.0 liter	30 minutes
2.0 liters	1 hour
3.0 liters	1.5 hours
4.0 liters	2.0 hours
5.0 liters	2.5 hours
6.0 liters	3.0 hours
7.0 liters	3.5 hours

Timer Settings

The MLVH-10A should be allowed to run for a half hour after all chemical has been expelled into the air. See the chart below for approximate amount of time it takes to expel chemicals. These times were compiled with clear water - the expulsion time may exceed these guidelines when mixed with chemicals.

Times may vary due to the consistency of solution being sprayed. Thicker solutions may take longer to discharge.

A video on programming your timer is available on our website.

How To Set The Timer

1. Plug the AutoFog into the appropriate power source.
2. Set the clock to the correct time. The timer is a 24 hour timer for accuracy between day and night.
3. Determine the spray starting time and stopping time.
4. Flip ALL of the pins between the starting and stopping time to the OUTSIDE. (see photo below)
5. The AutoFog will run only during the time that the pins are flipped to the outside of the clock. DO NOT FLIP THE START TIME AND STOP TIME ONLY. Each pin represents 15 minutes of time.
6. The AutoFog is now ready and will begin fogging at the appropriate time. Make sure the treatment area is secure and will be empty of all personnel at that time.

NOTE:

Remember to add a half hour to the spraying time when setting the timer.



Cleaning & Maintenance

The key to successful results with the MLVH-10A is keeping the machine clean. There are only a few steps involved, so it will be very easy. *Be sure to clean the machine after every use.*

- Using warm water and a soft cloth wash:
 - The Solution tank
 - The Solution tank cover
 - The Agitator blades
 - The Suction tube
 - Spray clear water through nozzle
 - Wipe off the machine

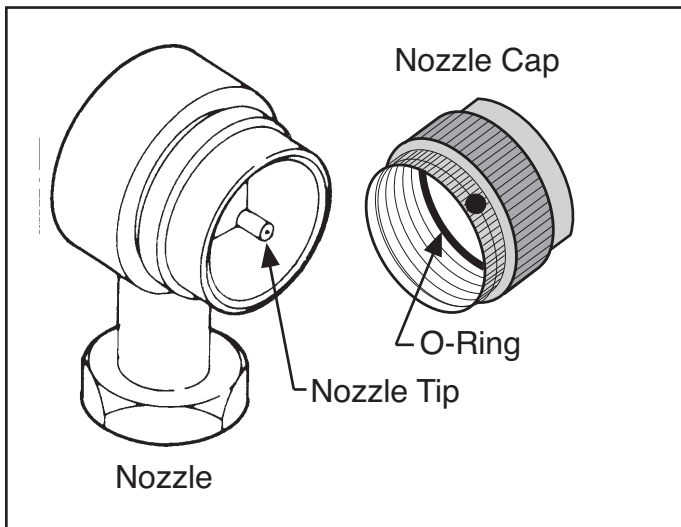

- Remove the nozzle from the MLVH-10A by unscrewing the securing nut. Remove the nozzle cap and wipe off any chemical residue. Always handle the nozzle and cap with care, especially the nozzle tip (see diagram below). Inspect the nozzle cap O-ring for damage or wear.

NOTE:

This procedure is necessary after every application of wettable powder solutions. Be sure to remove the nozzle cap and clean the nozzle.

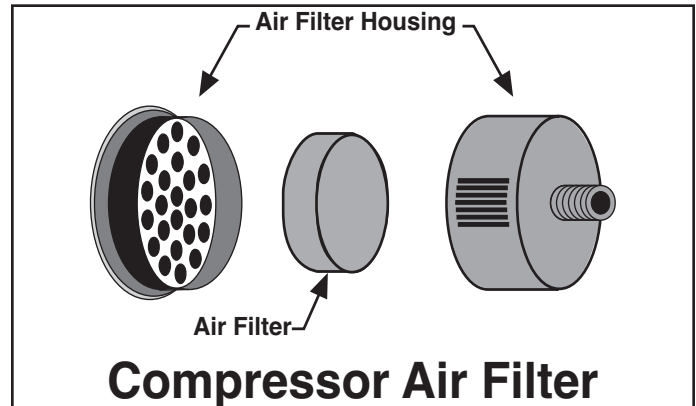

Compressor Air Filter

REPLACE FILTER ONCE A YEAR OR AFTER 500 HOURS OF USE.

- After every 25 hours of use, be sure to clean the air filter (Located under the compressor housing, on top of the compressor). Brush any excess debris off the filter and then rinse with warm water. Use a mild detergent if necessary. **ALWAYS** let the filter air dry completely before reinstalling.

NOTE:

The air filter will contain particles of the chemicals you have been applying. When cleaning the filter follow all EPA Guidelines for the handling and disposal of chemicals.

- Store the MLVH-10A where it is away from excessive moisture, children and unauthorized personnel. If you are storing the MLVH-10A for a long period of time, cover the equipment with a plastic sheet.

A video showing the cleaning procedure for the MLVH is available on our website.

Dramm offers an Annual Maintenance Kit (AMK) to keep your AutoFOG in top shape. Contact us annually to order this kit.

A video showing the maintenance involved in the AMK is available on our website.

MLVH-10A Assembly Diagram

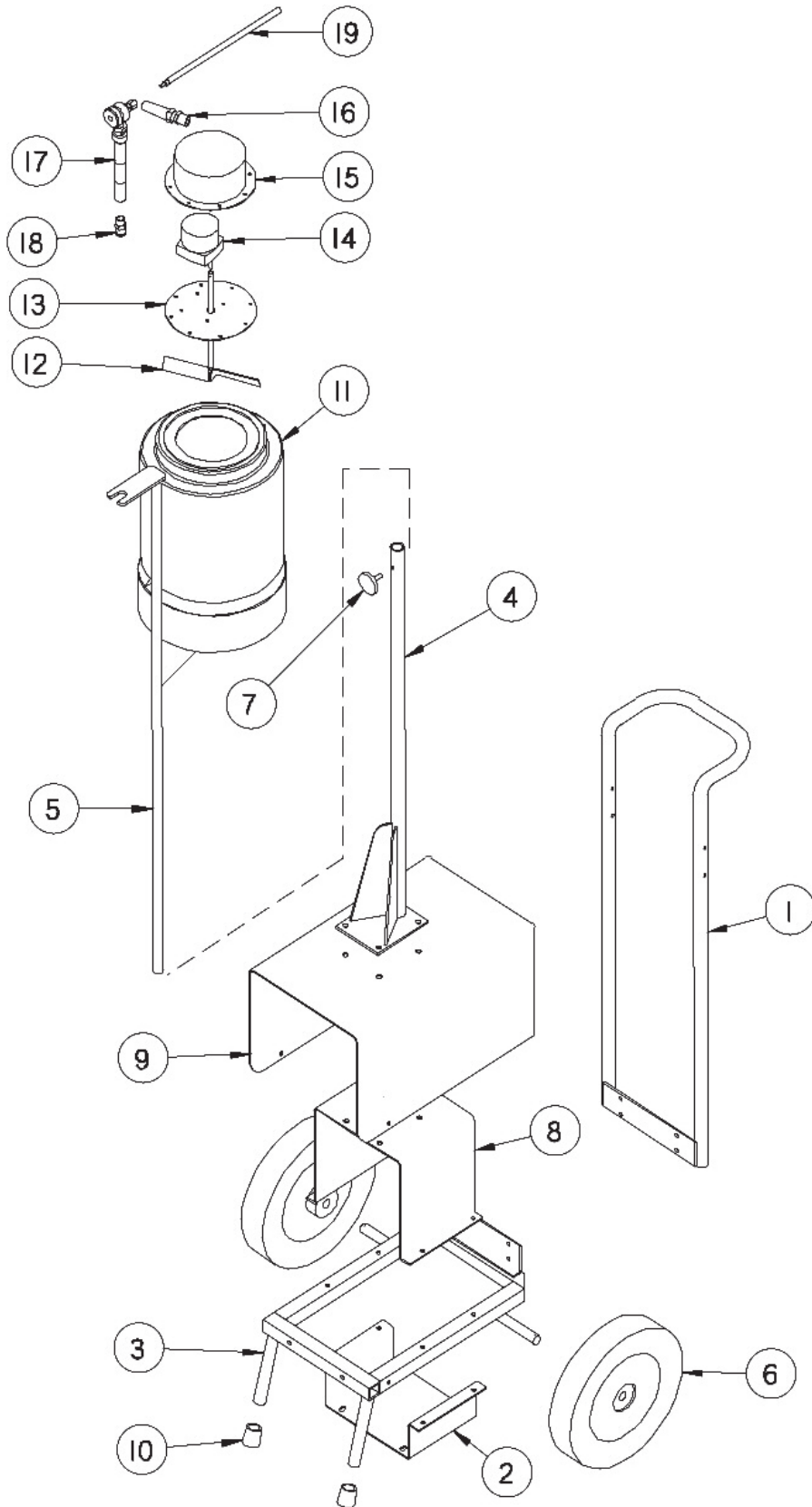

MLVH-10A Assembly Parts List

Item	Vendor #	Description	QTY	DRAMM #
1	DI0789	HANDLE ASSEMBLY	1	DI0789
2	DI0787A	COMPRESSOR CRADLE	1	DI0787A
3	DI0792	UNIT FRAME	1	DI0792
4	DI0649	LOWER NOZZLE STAND	1	DI0649
5	DI0114C	UPPER NOZZLE STAND	1	DI0114C
6	SNI0275-OP	10 X 2 WHEEL	2	500006
7	3035-AW	HAND KNOB	1	114054
8	DI0793	FRAME SUPPORT	1	DI0793
9	DI0798	RED COVER	1	DI0798
10	3/4 RUBBER TIP	3/4 RUBBER TIP	2	3/4 RUBBER TIP
11	DI0109	MLVH TANK	1	DI0109
12	DI0120	AGITATOR BLADE	1	DI0120
13	DI0116A	AGITATOR PLATE	1	DI0116A
14	PB-6A179	MOTOR AGITATOR	1	PB-6A179
15	DI0117A	AGITATOR COVER	1	DI0117A
16	3254	3/8" STRAIN RELIEF	1	300504
17	D7513670000A	NOZZLE ASSEMBLY	1	D7513670000A
18	442071	3/8 TUBE TO 1/4 NPT PUSH CONN.	1	220800
19	DI0151A	SUCTION TUBE	1	DI0151A

MLVH-10A Accessories

Part #	Description	Qty.
500926M	Graduated Cylindar	1
Funnel LVM100	Funnel	1
153582	Strainer	1

these items do not appear in the diagram.

MLVH-10A Compressor Plumbing

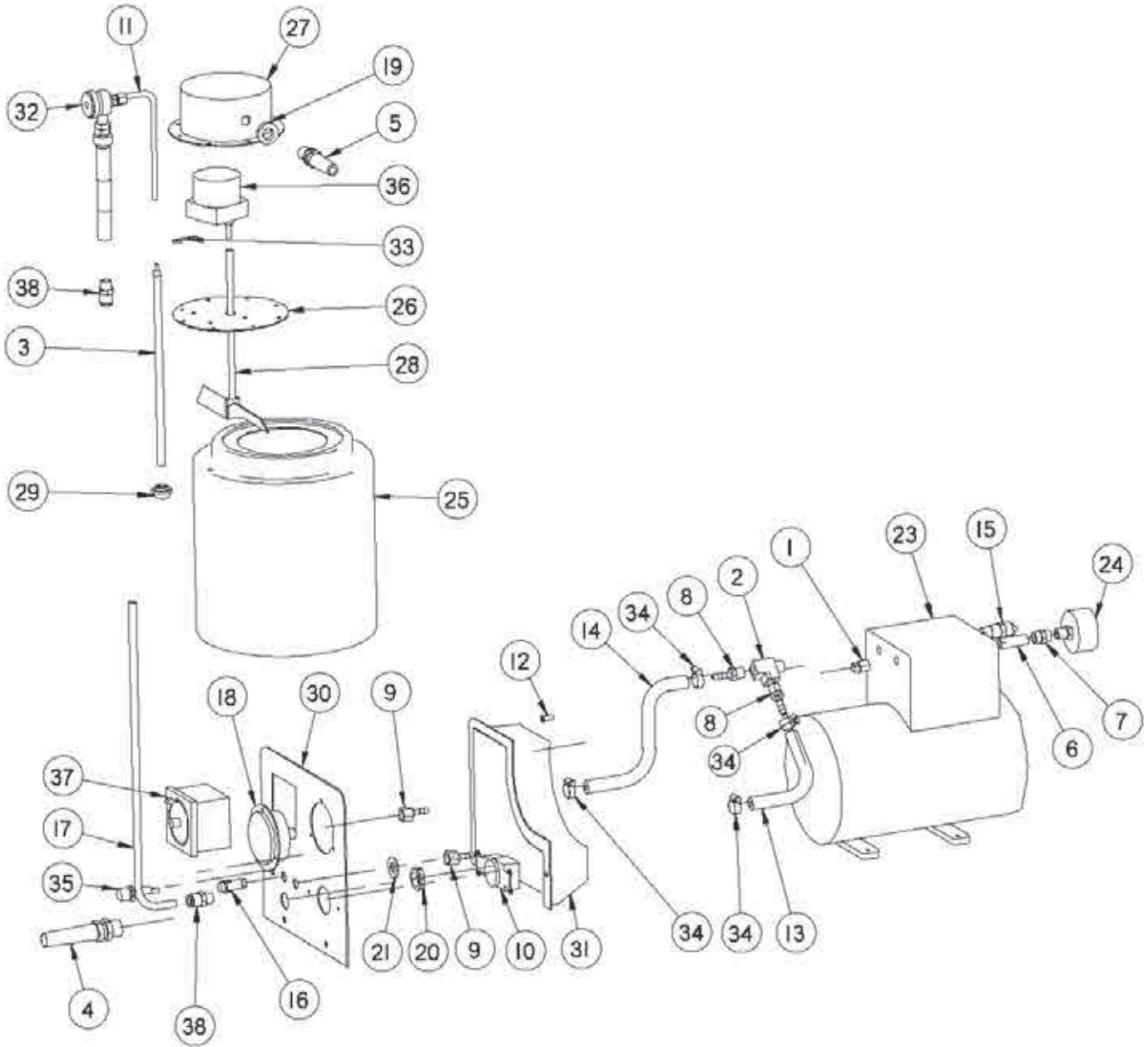

MLVH-10A Compressor Plumbing Parts List

Item	Vendor #	Description	QTY	DRAMM #
1	109-B-04	1/4" PLUG	1	220651
2	127-B-04	1/4 MALE RUN TEE	1	220604
3	D10151A	SUCTION TUBE	1	D10151A
4	3251	1/2" STRAIN RELIEF	1	300505
5	3254	3/8" STRAIN RELIEF	1	300504
6	40080	1/4 X 1/2 NIPPLE	1	220024
7	41279	1/4" COUPLING	1	220028
8	42777	BARB 1/4 x 1/4 PT BR	2	220207
9	43836	1/4 X 1/4 NPT BARB FITTING	2	220210
10	5015 LEVITON	RECEPTACLE	1	300305
11	INCLUDED	TUBE - COMES WITH NOZZLE	1	INCLUDED
12	50915k243	1/4" COMPRESSION TUBE FITTING	1	220357
13	5304K16	HOSE	1	250041
14	5304K16	HOSE	1	250041
15	5A707	RELIEF VALVE	1	5A707
16	5TF2LRN-1	Pilot light 120V RED	1	5TF2LRN-1
17	66PP	3/8 EASTMAN TUBE	1	251001
18	7016 2 1/2	PRESSURE GAUGE	1	260003
19	8461	3/8 NYLON NUT	1	114104
20	8463	1/2 NYLON NUT	1	114105
21	33086	1/2" FLAT WASHER	1	110304
23	9Z716	1208PK80 120V COMPRESSOR	1	620100
24	641010	AIR FILTER	1	641010
25	D10109	MLVH TANK	1	D10109
26	D10116A	AGITATOR PLATE	1	D10116A
27	D10117A	AGITATOR COVER	1	D10117A
28	D10120	AGITATOR BLADE	1	D10120
29	10388	SUCTION LINE STRAINER	1	290006
30	D10283C	CONTROL PANEL	1	D10283C
31	D11641	ELECTRICAL COVER	1	D11641
32	D7513670000A	NOZZLE ASSEMBLY	1	D7513670000A
33	h45289	hitch pin	1	118102
34	H62002	GEAR CLAMP	4	220400
35	HTB-261	FUSE HOLDER	1	HTB-261
36	PB-6A179	MOTOR AGITATOR	1	PB-6A179
37	SUL-189-H	24 HOUR TIMER	1	300304
38	442071	3/8 TUBE TO 1/4 NPT PUSH CONN.	2	220800

MLVH-10A Compressor Diagram

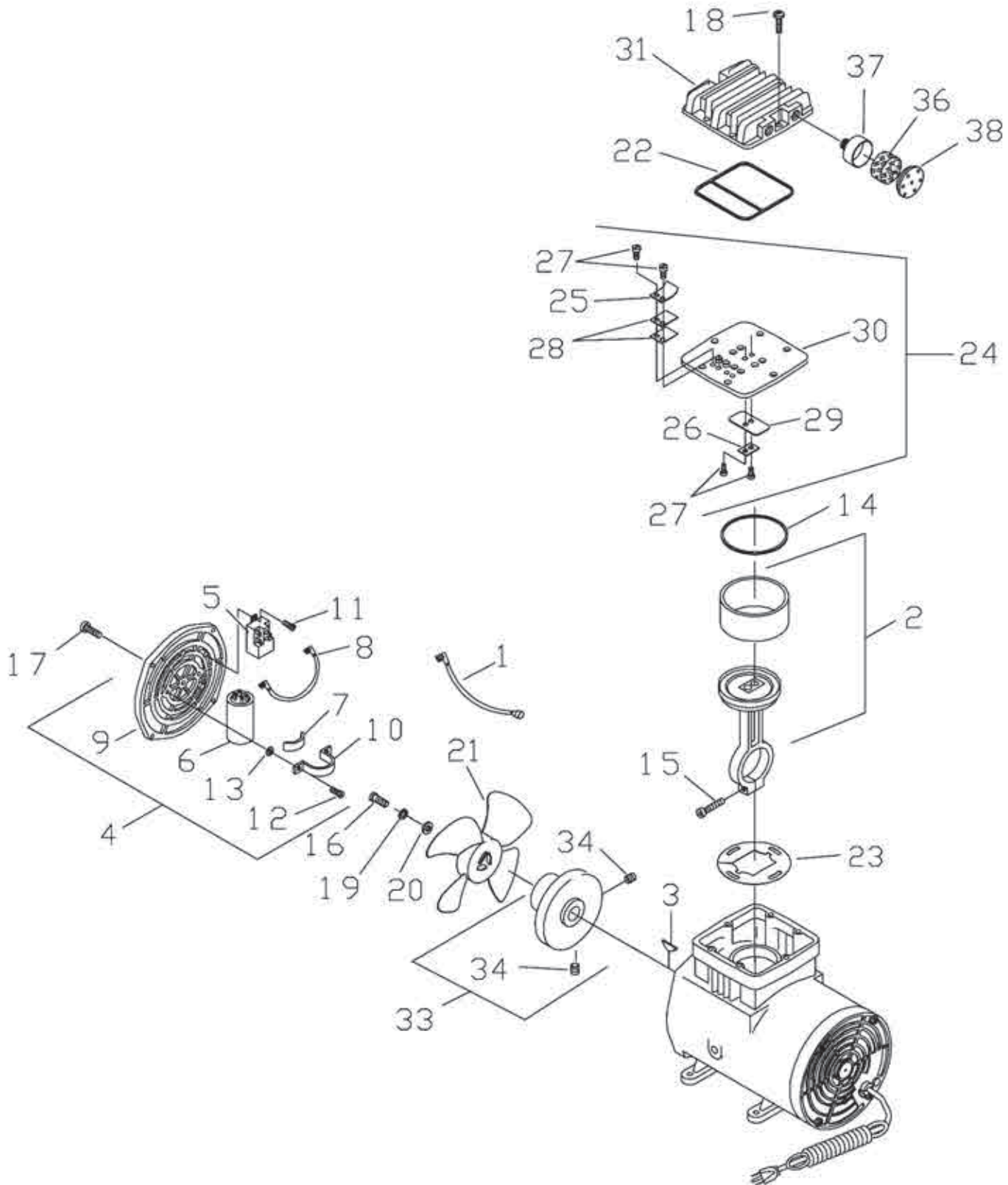

MLVH-10A Compressor Parts List

Item	Part No.		Description	Qty.
1	604128		Lead Wire (Brown)	1
*2	666527		Connecting Rod Ass'y	1
3	626618		Woodruff Key	1
4	671005		Front Cover Assembly	1
5		602215	Relay - 115V 60Hz	1
6		603021	Capacitor	1
7		604127	Foam Strip	1
8		604286	Lead Wire (Blue)	1
9		614509	Front Cover	1
10		617136	Capacitor Bracket	1
11		625245	Screw - Relay	2
12		625434	Screw -Capacitor Brkt.	2
13		626563	Washer	2
*14	623638		O-Ring - Valve Plate	1
*15	625114		Screw - Connecting Rod	1
16	625354		Screw - Fan	1
17	625448		Screw - Front Cover	4
*18	625583		Screw - Head	6
19	626509		Lockwasher	1
20	626563		Washer - Fan	1
21	633718		Fan	1
*22	638760		O-Ring - Head	1
23	638415		Dust Shield	1
24	662528-540		Valve Plate Ass'y - Black	1
*25		617124	Valve Flapper Restraint	2
*26		617135	Valve Keeper Strip	1
*27		625446	Screw - Valve Flapper	6
*28		656708	Valve Flapper	4
*29		656887	Valve Flapper	1
30		662520-540	Valve Plate - Black	1
31	661218-540		Head - Black	1
32	Not Used			
33	667194		Eccentric & Brg. Ass'y	1
34		625008	Set Screw	2
*36	641010		Filter	1
37	660776		Filter Body	1
38	660803		Filter Body Cap	1
N/S		638974	Safety Valve	1

MLVH-10A Nozzle Assembly

Item #	Part #	Component #	Description	Qty.
-	-	D7513670000A	Nozzle Assembly	1
1	7010		Nozzle Base	1
2	7020		Cap	1
3	7030		Lock Nut	1
5	7100		Extension Pipe	1
7	D10151		Stainless Suction Tube	1

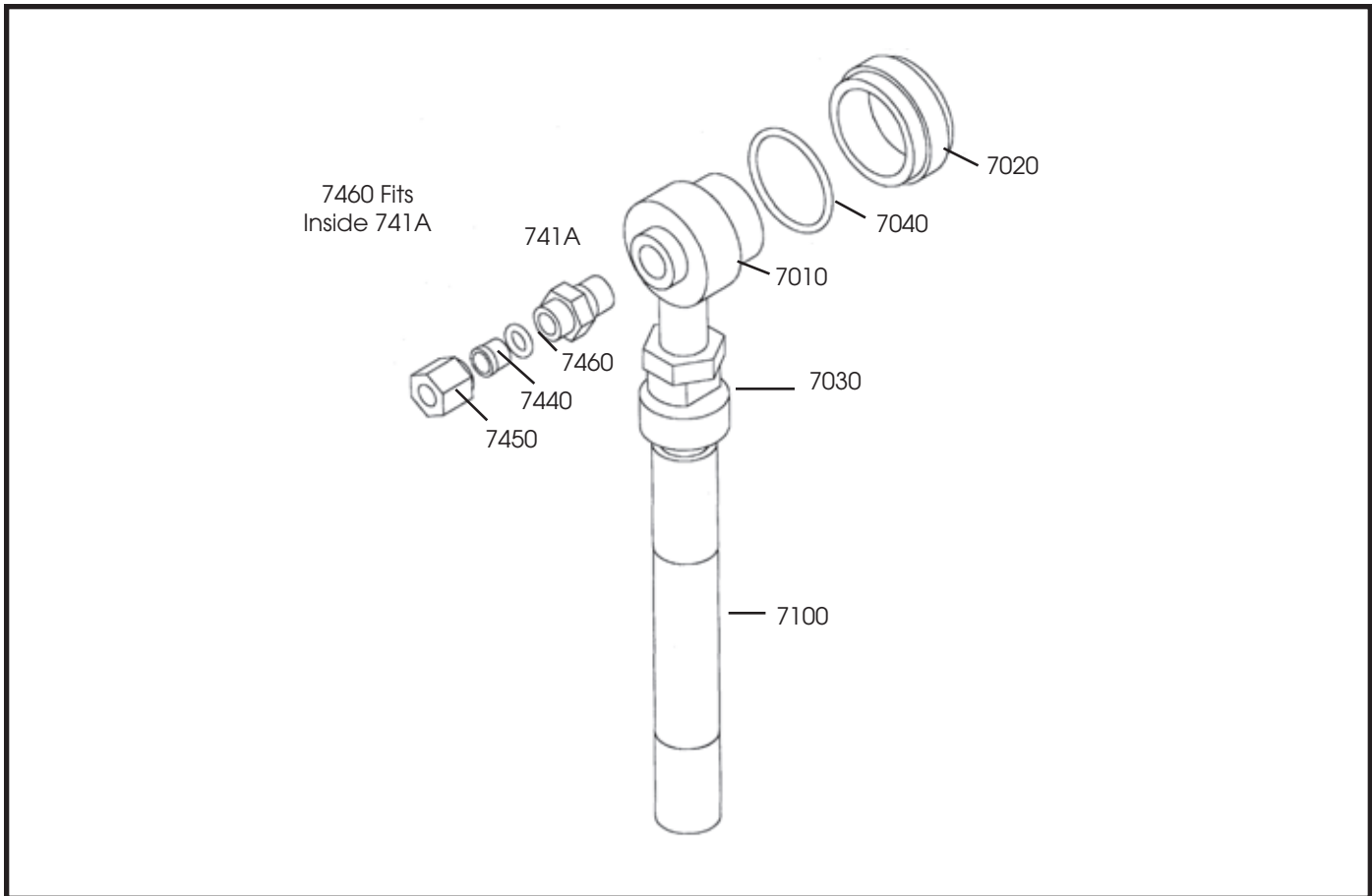

Troubleshooting

1. The spray pattern exits the nozzle in short bursts – it should exit as a steady stream.

A. The nozzle cap is not secure or properly lined up. Screw it on completely and then turn the cap counter clockwise so the two check marks on the nozzle line up. Check the nozzle calibration for 45cc/minute output rate. See diagram below.

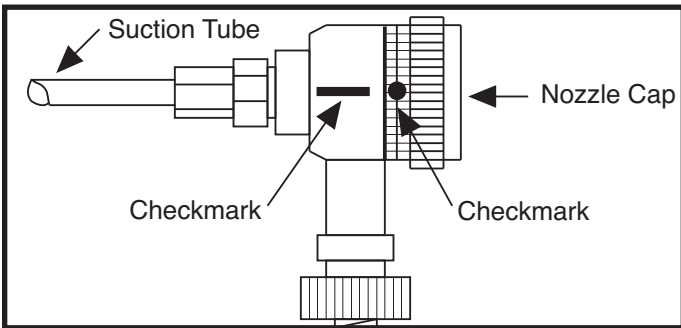

B. The nozzle cap has an O-Ring inside which may be damaged. Replace the O-Ring if it is cracked, broken or in some way damaged.

C. Inspect the suction tube for clogging or damage. To remove the suction tube from the nozzle first loosen the nut that holds the tube to the nozzle. Now, pull the tube out of the nozzle. Notice the metal sleeve on the tube, inspect it carefully. In most cases the sleeve must be replaced if it is damaged, dented, bent or cracked.

DO NOT OVER TIGHTEN NUT

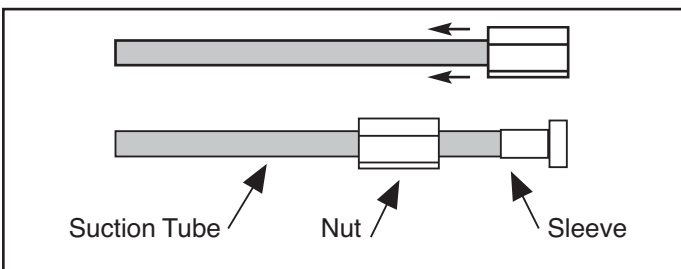

D. The nozzle and/or solution tank may be clogged with chemical residue. Soak the nozzle overnight, then clean the inside of the nozzle.

E. The suction tube may be clogged or damaged. With a gloved hand, cover the nozzle tip. This reverses the flow of air and blows the suction tube clean of any debris. Remove and clean the tube or replace it if necessary. See the diagram below.

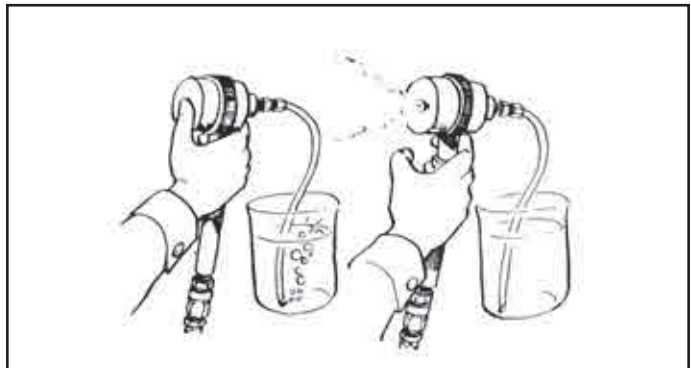

NOTE:

ALWAYS wear a glove when covering the nozzle.

F. The suction tube is above the surface of the solution in the tank. Make sure the suction tube is pushed down completely.

G. The filter at the bottom of the stainless steel suction tube is clogged and needs cleaning. Inspect the entire suction tube for clogging.

Continued on the next page...

Troubleshooting continued...

2. No spray exits the nozzle.
 - A. Insufficient air flow from the compressor may be caused by clogged piping or a dirty air filter. Check the piping and clean dirty filters.
 - B. The suction tube is not connected properly or is damaged and is leaking air into the nozzle which disrupts the venturi effect. Replace the suction tube and its connector.
 - C. The air hose may be loose and leaking air. Tighten the air hose connection at the nozzle and at the compressor.
3. Pressure gauge reads too low.
 - A. Air is leaking from the nozzle. Inspect the nozzle cap for proper installation.
 - B. Air is leaking from the suction tube. Replace the defective suction tube.
 - C. The piston and piston ring in the compressor is worn out. Replace both.
 - D. The pressure gauge may be defective or broken.
Replace it.
4. Pressure gauge reads too high.
 - A. Piping is clogged. Check the entire piping for obstructions and replace any defective or clogged sections.
 - B. A clogged nozzle or nozzle cap will cause pressure to rise. Clean thoroughly.
5. Abnormal noise or vibration.
 - A. The compressor anchor bolts are loose causing vibration. Re-tighten nuts and bolts.
 - B. The compressor set-up vibrates due to unstable position. Set the compressor on stable ground when operating.
6. Chemical flocculation (clumping) in the chemical tank.
 - A. Few chemicals will be subject to this phenomenon due to over agitation. For these chemicals use distilled water or discontinue use.
7. Machine runs for a short time and then stops.
 - A. Use a 12 gauge extension cord no longer than 50 feet.
 - B. Check power source for appropriate voltage and amperage (120 volt - 15amp).
 - C. Check fuse on control panel.
 - D. Clean the compressor air filter. When it is clogged it will cause the motor to overheat.

