



Signet 2850 Conductivity/Resistivity Sensor Electronics (PVDF)



3-2850.090-2 Rev. 4 09/20

Operating Instructions

3-2850-51, 3-2850-52
with 3/4-in. adapter



3-2850-61, 3-2850-62, 3-2850-63
with Universal adapter



3-2850-51-XXV(D), 3-2850-52-XXV(D)
PVDF Integral System



- [English](#)
- [Deutsch](#)
- [Français](#)
- [Español](#)
- [Italiano](#)
- [中文](#)

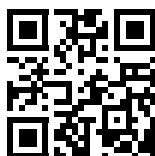

Description

- Signet 2850 Conductivity/Resistivity Sensor Electronics provides either a two-wire 4 to 20 mA output or Digital (S³L) format.
- The 4 to 20 mA output models provide eight ranges for each electrode cell constant, plus the ability to invert each range.
- The EasyCal feature allows the devices to automatically recognize standard conductivity test solution values for simple field calibration.
- The Conductivity Sensor provided with integral systems will have its custom cell constant information programmed into the electronics at the factory to provide a 2% sensor accuracy. See page 6 for details.

Table of Contents

Description.....	1
Dimensions.....	1
Warranty Information.....	2
Product Registration.....	2
Safety Information.....	2
Specifications.....	2
Conductivity Sensor Dimensions.....	3
Operating Range Chart.....	3
In-Line Installation.....	4
Tank Installation.....	4
4 to 20 mA Wiring.....	5
Digital (S ³ L) Wiring.....	5
Dual Input Wiring (Dual Digital (S ³ L) Output).....	5
Cell Constant Selection.....	6
Range Selection for 4 to 20 mA Output.....	7
Calibration.....	8
EasyCal.....	8
Dual Input Calibration.....	8
Maintenance.....	9
Troubleshooting.....	9
Electronic Certification.....	10
Ordering Information.....	12

Dimensions

2850-51, -52 Integral mount

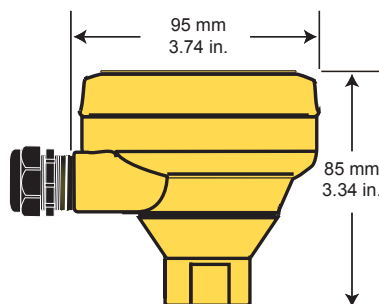

2850-61, -62, -63 Universal mount

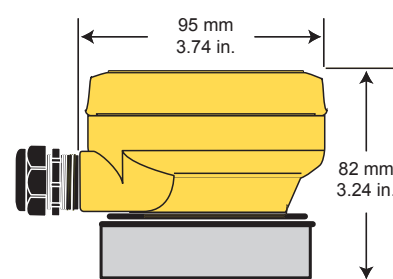

Warranty Information

Refer to your local Georg Fischer Sales office for the most current warranty statement.

All warranty and non-warranty repairs being returned must include a fully completed Service Form and goods must be returned to your local GF Sales office or distributor. Product returned without a Service Form may not be warranty replaced or repaired.

Signet products with limited shelf-life (e.g. pH, ORP, chlorine electrodes, calibration solutions; e.g. pH buffers, turbidity standards or other solutions) are warranted out of box but not warranted against any damage, due to process or application failures (e.g. high temperature, chemical poisoning, dry-out) or mishandling (e.g. broken glass, damaged membrane, freezing and/or extreme temperatures).

Product Registration





Thank you for purchasing the Signet line of Georg Fischer measurement products.

If you would like to register your product(s), you can now register online in one of the following ways:

- Visit our website www.gfsignet.com. Under **Service and Support** click on **Product Registration Form**
- If this is a pdf manual (digital copy), [click here](#)

Safety Information

1. Depressurize and vent system prior to installation or removal.
2. Confirm chemical compatibility before use.
3. Do not exceed maximum temperature/pressure specifications.
4. Wear safety goggles or faceshield during installation/service.
5. Do not alter product construction.
6. When using chemicals or solvents, care should be taken and appropriate eye, face, hand, body, and/or respiratory protection should be used.

	Caution / Warning / Danger Indicates a potential hazard. Failure to follow all warnings may lead to equipment damage, injury, or death
	Electrostatic Discharge (ESD) / Electrocutation Danger Alerts user to risk of potential damage to product by ESD, and/or risk of potential of injury or death via electrocution.
	Personal Protective Equipment (PPE) Always utilize the most appropriate PPE during installation and service of Signet products.
	Pressurized System Warning Sensor may be under pressure, take caution to vent system prior to installation or removal. Failure to do so may result in equipment damage and/or serious injury.
	Note / Technical Notes Highlights additional information or detailed procedure.

Specifications

General

Compatible Electrodes Any Signet Conductivity/Resistivity electrode (2818-2823, 2839-2842)
 Temperature Compensation PT-1000 RTD (2% per °C)
 Pure Water Compensation Auto-switching when using 0.01 cell and raw conductivity value < 0.5 µS

EasyCal

Automatic recognition of the following conductivity values:

- 146.93 µS, 1408.8 µS, 12856 µS (@ 25 °C)
(Test solutions per ASTM D1125-95)
- 10 µS, 100 µS, 200 µS, 500 µS, 1000 µS, 5000 µS, 10,000 µS, 50,000 µS, 100,000 µS (@ 25 °C)

Power

- 12 to 24 VDC (4 to 20 mA output)
- 5 VDC ±5% regulated, 3.0 mA max. for Digital (S³L) output (Reverse polarity and short circuit protected)

Digital (S³L) Output..... Serial ASCII, TTL level 9600 bps

Accuracy

- Conductivity ±2% of reading
- Temperature..... ±0.5 °C

Resolution

- Conductivity 0.1% of reading
- Temperature..... < 0.2 °C

Update Rate

- Single Input models < 600 ms
- Dual Input models < 1.2 s

Current Output

Field-selectable ranges. Factory set span:

- 0.01 cell (2818, 2819, 2839)..... 4 to 20 mA = 0 to 100 µS
- 0.10 cell (2820, 2840)..... 4 to 20 mA = 0 to 1000 µS
- 1.0 cell (2821, 2841)..... 4 to 20 mA = 0 to 10,000 µS
- 10.0 cell (2822, 2842)..... 4 to 20 mA = 0 to 200,000 µS
- 20.0 cell (2823)..... 4 to 20 mA = 0 to 400,000 µS

Max. Loop Resistance 50 Ω @ 12 VDC
 325 Ω @ 18 VDC
 600 Ω @ 24 VDC

Accuracy..... ±2% of output span

Resolution..... 7 µA

Update Rate <600 ms

Error Indication 22 mA

Available data via Digital (S³L) Output

- Raw conductivity
- Calibrated conductivity
- Calibrated temperature-compensated conductivity
- Temp. Error Indication..... Open input and out-of-range diagnostics for temperature or internal electronic error.

Environmental

Material..... PBT

Enclosure Rating NEMA 4X/IP65

Operating Temperature..... -10 to 85 °C (14 to 185 °F)

Storage Temperature..... -20 to 85 °C (-4 to 185 °F)

Relative Humidity..... 0 to 95%, non-condensing

Shipping Weight 0.75 kg (1.75 lb.)

Standards and Approvals

- CE, RoHS Compliant
- Manufactured under ISO 9001 for Quality, ISO 14001 for Environmental Management and OHSAS 18001 for Occupational Health and Safety.

 China RoHS (Go to www.gfsignet.com for details)

FC This device complies with Part 15 of the FCC rules.

Operation is subject to the following two conditions:

- (1) This device may not cause harmful interference, and
- (2) This device must accept any interference received, including interference that may cause undesired operation.

Conductivity Sensor Dimensions

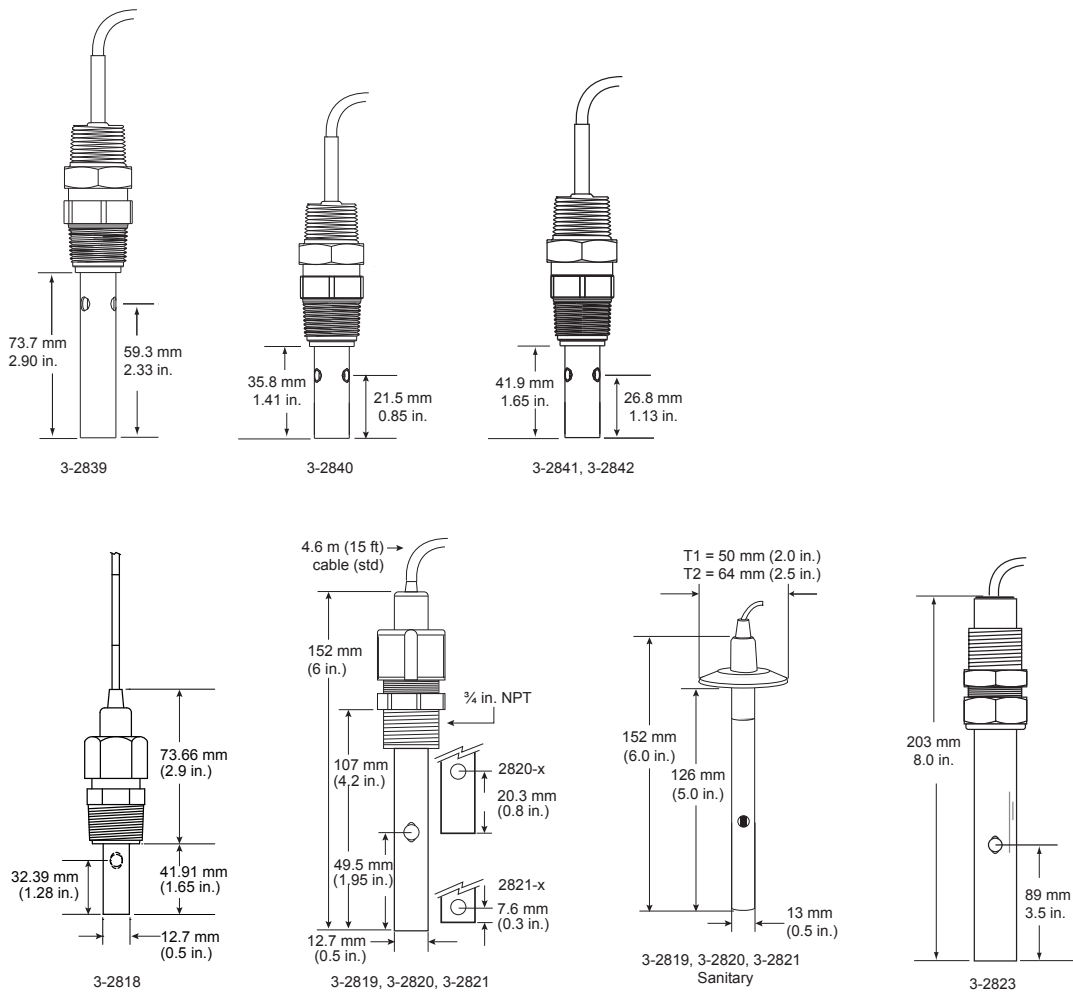

Operating Range Chart

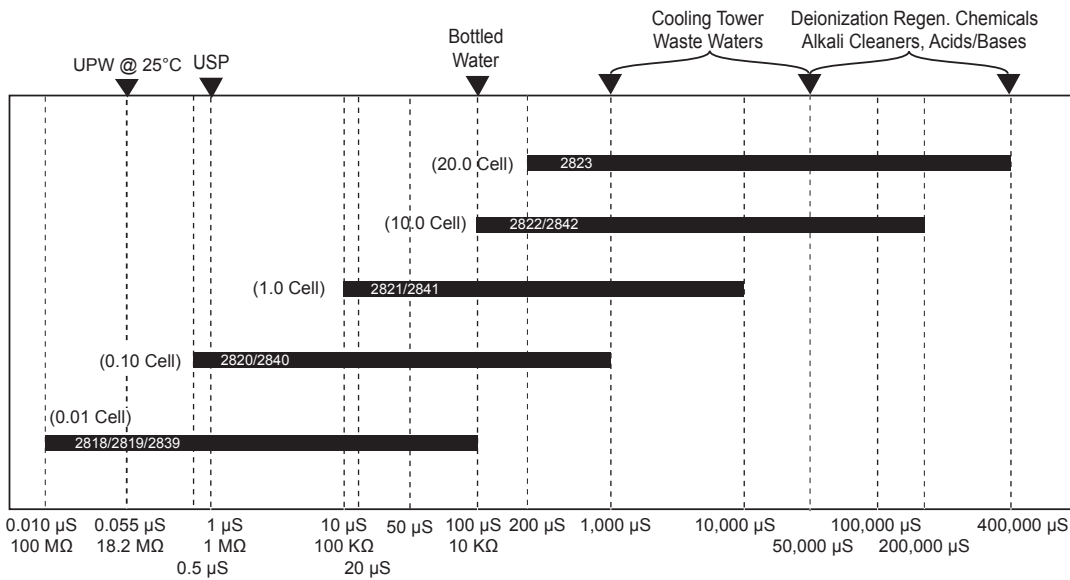

In-Line Installation

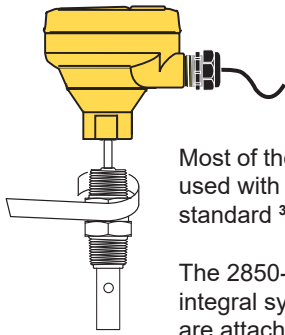

Most of the Conductivity/Resistivity electrodes used with the 2850 can be installed into standard $\frac{3}{4}$ in. (NPT or ISO 7-R $\frac{3}{4}$) fittings.

The 2850-5X models are designed for integral systems, where the electronics are attached directly to the sensor.

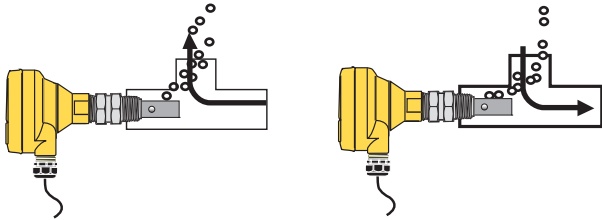

The preferred installation for in-line applications directs flow straight into the electrode. This configuration reduces the probability of entrapped air bubbles, and provides the best continuous sampling of the fluid content.

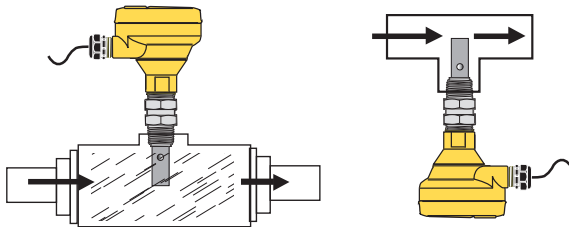

If the electrode is mounted vertically in a tee, do not recess the electrode orifices inside the tee. Mounting upside down may help prevent air entrapment.

An oversized tee or flow cell may be helpful for inline installations.

At least 4 threads (ANSI B1.20.1) must be engaged to meet the pressure rating as published in the specifications.

Use the 2850-6X models for in-line installations where the electronics must be separated from the electrode.

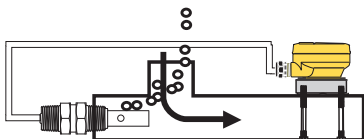

Conductivity electrodes with sanitary flange fittings must be installed using this option.

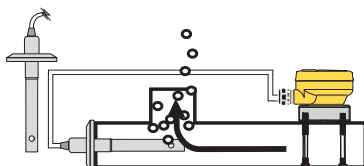

Tank Installation

While the 2850-5X and 2850-6X electronics cannot be submerged, either model will accommodate tank installation.

Select any electrode with a 5 m (15 ft) cable. The cable may be cut to length, but it **CANNOT BE EXTENDED**.

The universal adapter included with 2850-6X models can be attached to the top of a tank or mounted to a surface near the tank.

Adapt the 2850-5X models to tank installations by attaching a clamp to the conduit.

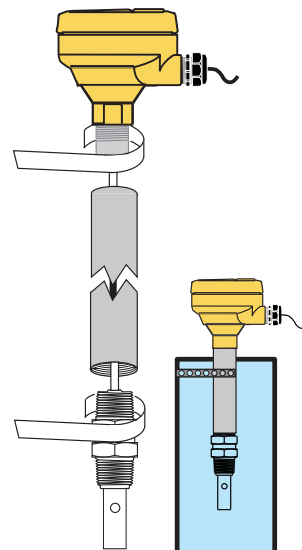
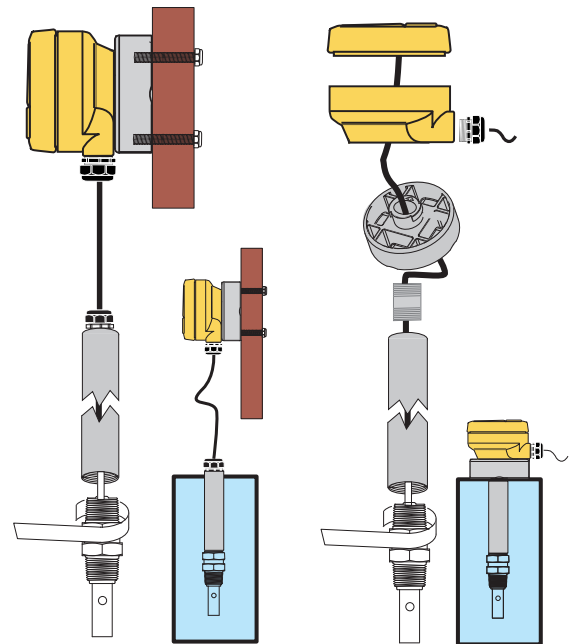

4 to 20 mA Wiring

Maximum length of 4 to 20 mA loop is 300 meters (1000 ft)

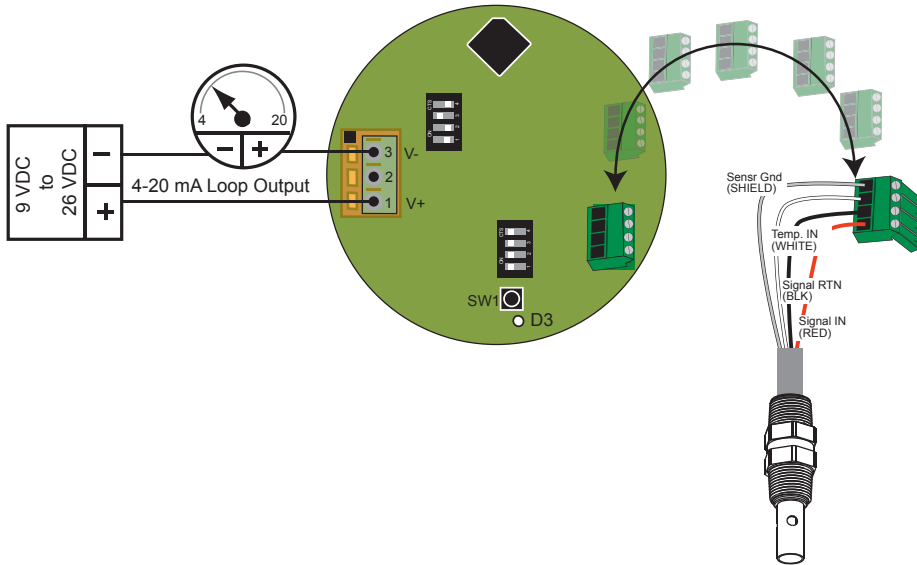

Digital (S³L) Wiring

The Digital (S³L) output is compatible with the Signet 8900 Multi-Parameter Controller and the Signet 9900 Transmitter.

Refer to the wiring sections of the 8900 or 9900 manual to determine cable length limitations.

IMPORTANT: Provide Earth Ground as indicated by  symbol.

Note: The 2819-2823 and 2839-2842 sensors can connect directly to the 9900 via the 9900's optional Direct Conductivity/Resistivity Module 3-9900.394 (159 001 699).

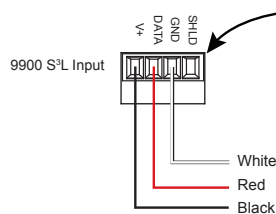
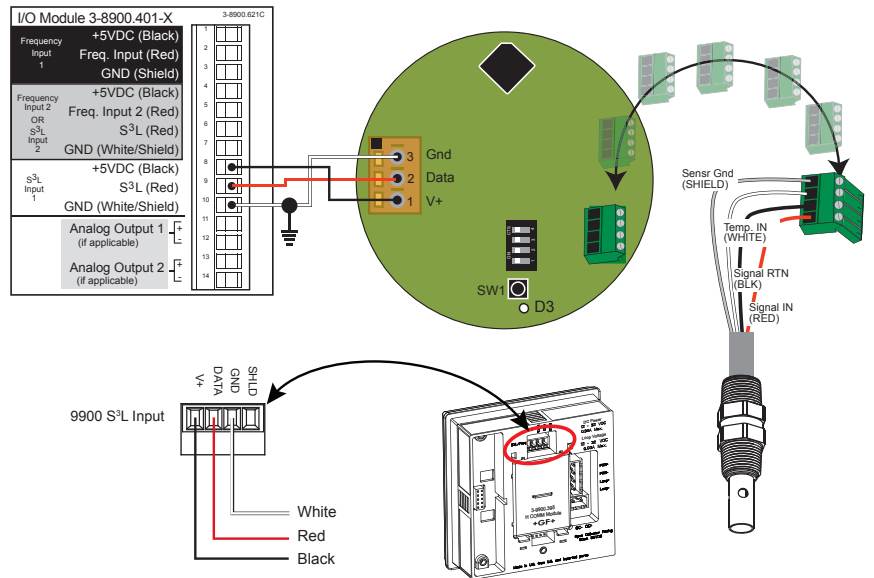

Dual Digital (S³L) Input Wiring

Dual Input is available on Digital (S³L) output model 3-2850-63 only, for use with the Signet 8900 Multi-Parameter Controller.

Sensors may be the same or different cell constants.

If the Dual Input model is used with a single sensor, connect the sensor to Input 1 and set all of the Input 2 switches to OFF (OPEN).

Dual Input applications usually include one sensor with a smaller cell constant and one sensor with a larger cell constant. **Place the larger cell constant on Input 1.**

This allows periodic recalibration of the larger cell by simply turning Input 2 OFF (OPEN).

IMPORTANT: Provide Earth Ground as indicated by  symbol.

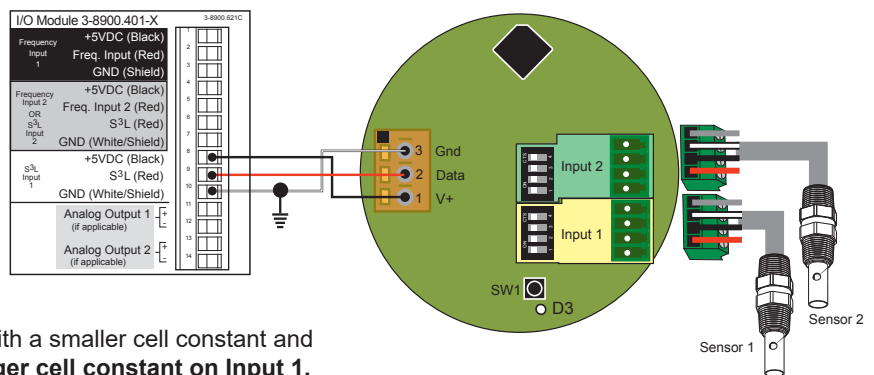

Cell Constant Selection

Single Input 2850 Electronics (2850-51, 2850-52, 2850-61, 2850-62)

- Single input models use only SW3.
- Use SW3 #1-3 to select the cell constant for the first sensor.
- Use SW3 #4 to disable the PT1000 Temp Compensation function in the 2850 (as required for USP applications).
- Recommended:
Make all switch settings before supplying power. Switch changes made after supplying power will take 15 to 20 seconds before becoming effective.

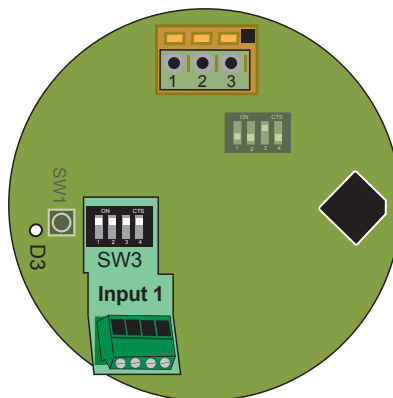

Integral 2850 Systems (Single Input)

- The 2850-51-XX and 2850-52-XX are shipped from the factory with the custom cell constant and temperature offset programmed into the single-input electronics.
- SW3 will be preset to "Custom cell constant".
- No additional modifications are required.

Replacing Integral System Electrode or Electronics

- When installing a new conductivity electrode or replacing System Electronics, the SW3 switches must be configured to select the appropriate cell constant.
- See Single Input section above.
- Leaving SW3 in the custom cell constant configuration will effect accuracy.
- Use calibration standards to calibrate (see page 8).

Dual Input 3-2850-63 Electronics

- Switch banks SW3 and SW4 are used to select the cell constant of the electrodes.
- Use SW3 #1-3 to select the cell constant for the first sensor.
- Use SW3 #4 to disable the PT1000 Temp Compensation function in the 2850 (as required for USP applications). This disables the function for BOTH INPUTS.
- Use SW4 #1-3 to select the cell constant for the second sensor.
- Set SW4 #4 to OPEN to disable Input 2.
- Recommended:
Make all switch settings before supplying power. Switch changes made after supplying power will take 15 to 20 seconds before becoming effective.

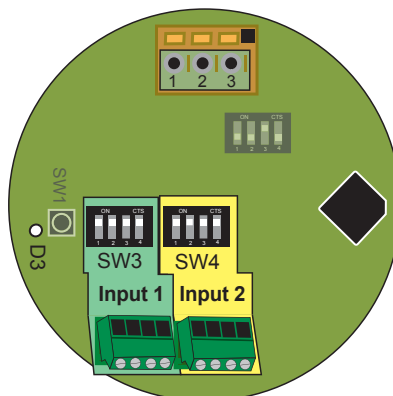

NOTE: Dual Input applications usually include one sensor with a smaller cell constant and one sensor with a larger cell constant. **Place the larger cell constant on Input 1.** This allows periodic recalibration of the larger cell by simply turning Input 2 OFF (OPEN).

SW3 = Cell Constant and Temperature Compensation					SW4 = Cell Constant and Input 2				
#1	#2	#3	#4	Cell Constant	#1	#2	#3	#4	Cell Constant
C	C	C	O	Custom	C	C	C	O	Custom
C	O	O	O	0.01 cm ⁻¹	C	O	O	O	0.01 cm ⁻¹
O	C	O	O	0.1 cm ⁻¹	O	C	O	O	0.1 cm ⁻¹
C	C	O	O	1.0 cm ⁻¹	C	C	O	O	1.0 cm ⁻¹
O	O	C	O	10.0 cm ⁻¹	O	O	C	O	10.0 cm ⁻¹
C	O	C	O	20.0 cm ⁻¹	C	O	C	O	20.0 cm ⁻¹
#4: (O) Open = Temp Comp ACTIVE (C) Closed = Temp Comp INACTIVE					#4: (O) Open = Input 2 INACTIVE (C) Closed = Input 2 ACTIVE				

NOTE:

To work correctly with the 9900, the 2850 must be set for the custom cell constant or the actual electrode cell constant and the 9900 set for a 1.0 cell constant.

SW3 or SW4

Custom Cell Constant

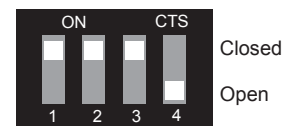

0.01/cm⁻¹

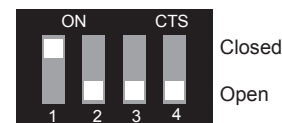

0.1/cm⁻¹

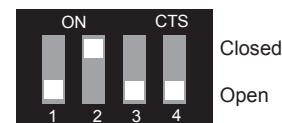

1.0/cm⁻¹

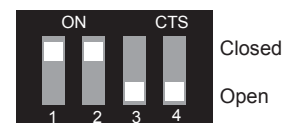

10.0/cm⁻¹



20.0/cm⁻¹

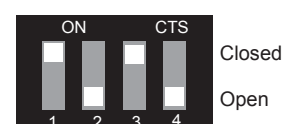

Examples

1.0 cell constant, temp comp **Active**



1.0 cell constant, temp comp **Inactive**

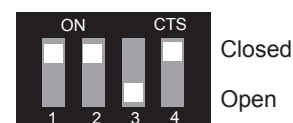

Range Selection for 4 to 20 mA Output

- The Range selection switch bank (SW2) provides eight range selections for each cell constant.
- Each range can be inverted, making a total of 16 range options.
- Select a range from the table below and set SW2 as indicated.

Example (refer to shaded selections of chart):

- The electrode installed is the 3-2840-1V, with a 0.10 cell constant.
- The required output is 4 to 20 mA = 0 to 100 μ S.
- Set SW2 switch bank to C-C-O-O.
- To invert range (4 to 20 mA = 100 to 0 μ S), close switch #4.

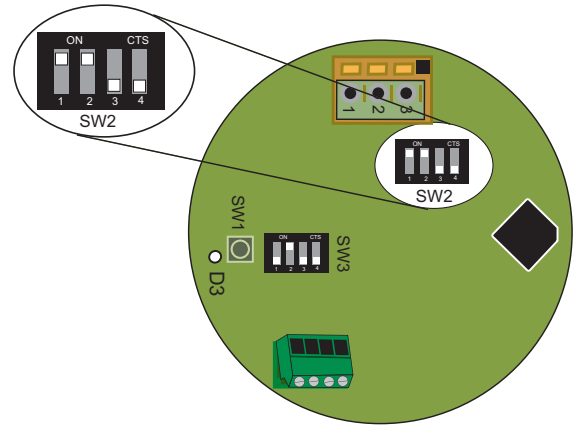

SW2 Switch Setting				0.01 Cell	0.10 Cell	1.0 Cell	10.0 Cell	20.0 Cell
#1	#2	#3	#4	Resistivity Ranges in BOLD				
C	C	C	O	10 to 20 MΩ	0 to 2 μ S	0 to 20 μ S	0 to 200 μ S	0 to 400 μ S
C	C	C	C	20 to 10 MΩ	2 to 0 μ S	20 to 0 μ S	200 to 0 μ S	400 to 0 μ S
O	C	C	O	2 to 10 MΩ	0 to 5 μ S	0 to 50 μ S	0 to 500 μ S	0 to 1000 μ S
O	C	C	C	10 to 2 MΩ	5 to 0 μ S	50 to 0 μ S	500 to 0 μ S	1 000 to 0 μ S
C	O	C	O	0 to 2 MΩ	0 to 10 μ S	0 to 100 μ S	0 to 1 000 μ S	0 to 2 000 μ S
C	O	C	C	2 to 0 MΩ	10 to 0 μ S	100 to 0 μ S	1 000 to 0 μ S	2 000 to 0 μ S
O	O	C	O	0 to 1 μ S	0 to 50 μ S	0 to 500 μ S	0 to 5 000 μ S	0 to 10 000 μ S
O	O	C	C	1 to 0 μ S	50 to 0 μ S	500 to 0 μ S	5 000 to 0 μ S	10 000 to 0 μ S
C	C	O	O	0 to 5 μ S	0 to 100 μS	0 to 1 000 μ S	0 to 10 000 μ S	0 to 20 000 μ S
C	C	O	C	5 to 0 μ S	100 to 0 μ S	1 000 to 0 μ S	10 000 to 0 μ S	20 000 to 0 μ S
O	C	O	O	0 to 10 μ S	0 to 200 μ S	0 to 2 000 μ S	0 to 50 000 μ S	0 to 100 000 μ S
O	C	O	C	10 to 0 μ S	200 to 0 μ S	2 000 to 0 μ S	50 000 to 0 μ S	100 000 to 0 μ S
C	O	O	O	0 to 50 μ S	0 to 500 μ S	0 to 5 000 μ S	0 to 100 000 μ S	0 to 200 000 μ S
C	O	O	C	50 to 0 μ S	500 to 0 μ S	5 000 to 0 μ S	100 000 to 0 μ S	200 000 to 0 μ S
O	O	O	O	0 to 100 μ S	0 to 1 000 μ S	0 to 10 000 μ S	0 to 200 000 μ S	0 to 400 000 μ S
O	O	O	C	100 to 0 μ S	1000 to 0 μ S	10 000 to 0 μ S	200 000 to 0 μ S	400 000 to 0 μ S

NOTE: Switch #4 inverts the loop output range

(O) Open = 4 to 20 mA

(C) Closed = 20 to 4 mA

Calibration

All 2850 Conductivity/Resistivity Sensor Electronics are factory calibrated for maximum out-of-the-box accuracy. The EasyCal feature allows calibration to be performed at the sensor.

The 2839-2842 Conductivity sensors come with a certificate of calibration. This certificate provides information regarding the actual cell constant and temperature offset as tested and verified according to NIST standards. This information has been programmed into the 2850 electronics as its default factory value. If required, the sensor can be recertified by contacting the GF Signet repair department.

- a. SW2: 4 to 20 mA output range selection switch bank
- b. Power and Output terminal block: 4 to 20 mA or Digital (S³L) Outputs
- c. SW3 and SW4: Electrode Cell Constant selection switch banks
- d. D3: LED indicator
- e. SW1: EasyCal Push-button
- f. Input 1 & Input 2: Conductivity Electrode connections

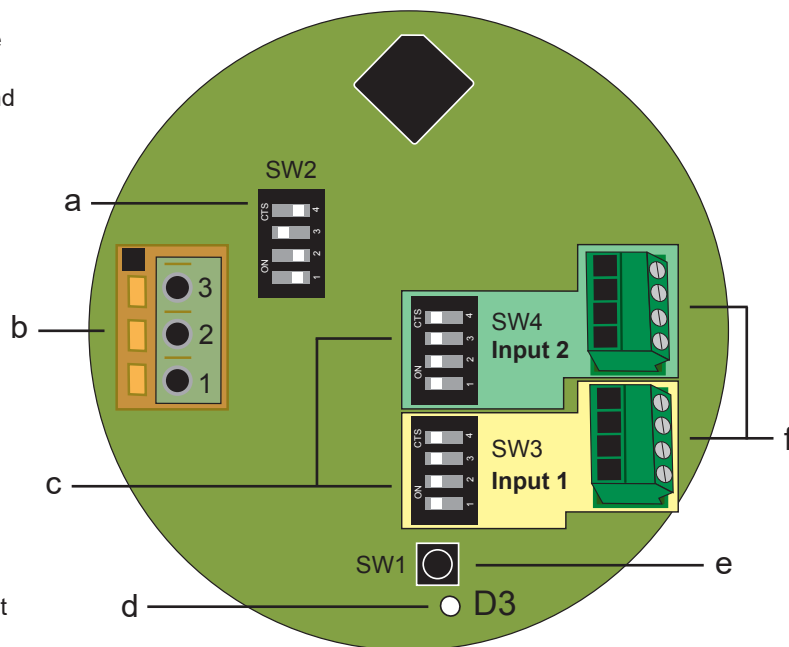

NOTE:

When the electrode is changed from its original factory provided electrode or the application requires a cell constant change, reset SW3 or SW4 switches (see page 6). Then perform a wet calibration with calibration standards.

EasyCal

EasyCal is a single-point calibration system. During this procedure, if the measured value is within $\pm 10\%$ of any of the test values listed below, the 2850 will automatically recognize the test value and calibrate the output to that value.

NOTE: Reset to factory calibration is required each time an electrode is replaced, and is **NOT** necessary on initial installation or periodic calibration.

To reset the 2850 Sensor to factory calibration: Set all switches on SW3 (and SW4 for Dual Input) to OPEN. Apply power, wait at least 3 seconds, then press and hold SW1 until the LED (D3) comes on steady then goes off again (approx. 10 seconds). When the LED goes off, release SW1; reset is complete. Reset SW3 and SW4 to the proper settings.

1. **Place** the electrode/sensor assembly into the conductivity test solution appropriate to your operating range. Shake the electrode to dislodge any air bubbles visible on the surface of the electrode.
 - 146.93 μS , 1408.8 μS , 12856 μS (per ASTM D1125-95)
 - 10 μS , 100 μS , 200 μS , 500 μS , 1000 μS , 5000 μS , 10,000 μS , 50,000 μS , 100,000 μS .

Allow at least 2 minutes for the electrode response to stabilize.

2. **Press** and hold SW1 for approximately 8 to 10 seconds. During this time, the LED will come on steady then go back off. (If the LED blinks several times rapidly, the calibration was not successful. See the troubleshooting section).

Calibration is complete. Return the system to service.

Dual Input Calibration

Dual Input 3-2850-63 Electronics

- The 2850-63 can only be calibrated if both inputs are used, or if Input 2 is disabled.
 - To disable Input 2: Set SW4, #4 to OPEN.
- Place each sensor into a test solution that represents the operating range of that sensor. When SW1 is pressed, the 2850 will calibrate both inputs simultaneously.
- Dual Input applications usually include one sensor with a smaller cell constant and one sensor with a larger cell constant. **Place the larger cell constant on Input 1.** This allows periodic recalibration of the larger cell by simply turning Input 2 OFF (OPEN).

Maintenance

The 2850 requires no periodic maintenance.

- Coatings on the electrode may cause slow response or drift.
- Clean metallic surfaces with a mild detergent and a non-abrasive brush or cotton swab.

Troubleshooting

LED and Output Condition	Possible Causes	Suggested Solutions
<p>Current Out: LED off, current output is 22 mA</p> <p>(S³L) out: "Check Sensor"</p>	<ul style="list-style-type: none"> • SW3 and SW4 set to all OPEN (factory setting). • No electrode installed. • SW3 (and SW4) not set correctly. • System not ready. 	<ul style="list-style-type: none"> • Normal for new system. • Install electrode. • Set SW3 and SW4 correctly. • Retry (recycle power).
<p>During EasyCal, the LED blinks rapidly for 4 seconds.</p>	<ul style="list-style-type: none"> • Measured value of the test solution is outside the $\pm 10\%$ tolerance. • The electronics or the electrode is defective. 	<ul style="list-style-type: none"> • Use fresh test solutions and restart the calibration. • Replace the electronics or the electrode.
<p>After completing calibration procedure, the output values are inaccurate.</p>	<ul style="list-style-type: none"> • Insufficient time allowed for electrode stabilization during calibration procedure. • Test solutions are contaminated. • EasyCal performed with temp comp Inactive, then temp comp Active for measurement. (or vice versa) 	<ul style="list-style-type: none"> • Recalibrate and wait at least 2 minutes after placing electrode in solution before pressing SW1. • Use fresh test solutions and restart the calibration.
<p>The output of the 2850 indicates a value that is off by a factor of 10 (e.g. 10x, 100x the correct value)</p>	<ul style="list-style-type: none"> • The cell constant selection on the 2850 (SW3 or SW4) does not match the actual input. 	<ul style="list-style-type: none"> • Match the 2850 switch settings to agree with the sensor being used.

Electronic Certification

Signet offers conductivity simulators in five different values. These tools enable the user to validate the performance of the electronics independently of the electrode. This requirement is defined by ASTM D 1125-95 (Standard Test Methods for Electrical Conductivity and Resistivity of Water) which is commonly used for USP 24 applications.



3-2850.101-1	(159 001 392)	1.0 μ S \pm 0.1%
3-2850.101-2	(159 001 393)	2.5 μ S \pm 0.1%
3-2850.101-3	(159 001 394)	10.0 μ S \pm 0.1%
3-2850.101-4	(159 001 395)	18.2 M Ω \pm 0.1%
3-2850.101-5	(159 001 396)	10.0 M Ω \pm 0.1%

Before using the Simulator:

Before using the simulators, disconnect all electrodes and reset the 2850 Electronics to factory calibration:

1. Set all switches on SW3 (and SW4 for Dual Input) to OPEN. Turn the power on, wait at least 3 seconds
2. Press and hold SW1 until the LED (D3) comes on steady then goes off again (approx. 10 seconds).
3. When the LED goes off, release SW1. Reset is complete.

To validate Input 1:

1. Turn the power off.
2. Set SW3 to accept a 0.01 cell constant. Leave SW4 in the all-OPEN position.
3. Install the simulator into the 2850 at the Input 1 conductivity electrode terminals.
4. Connect the 2850 output terminals to the appropriate display instrument. Turn the power on.
 - The display should indicate a conductivity value within \pm 2% of the simulator value.
 - If the output is x10 or x100 of the correct value, recheck step 2. The 2850 is not set to accept a 0.01 cell constant.
 - If the correct value is displayed, the electronics are calibrated to ASTM D 1125 specifications. Remove the simulator and reset SW3 to the correct cell constant before reinstalling the electrode.
 - If the correct value is not displayed, contact the factory.

To validate Input 2:

1. Turn the power off.
2. Set SW4 to accept a 0.01 cell constant.
3. Install the simulator into the 2850 at the Input 2 conductivity electrode terminals.
4. Set SW3 switches to the all-OPEN position.
5. Turn the power on and repeat step 4.

Remember to reset all switches to their correct position before resuming normal operation.

Ordering Information

Signet 2850 Conductivity/Resistivity Sensor Electronics

*All versions include EasyCal

Mfr. Part No.	Code	Description
3-2850-51	159 001 398	2850 Sensor Electronics with Digital (S ³ L) Output and ¾ inch adapter
3-2850-52	159 001 399	2850 Sensor Electronics with 4 to 20 mA Output and ¾ inch adapter
3-2850-61	159 001 400	2850 Sensor Electronics with Digital (S ³ L) Output and Universal adapter
3-2850-62	159 001 401	2850 Sensor Electronics with 4 to 20 mA Output and Universal adapter
3-2850-63	159 001 402	2850 Sensor Electronics with Dual Inputs, Dual Digital (S ³ L) Outputs and Universal adapter (for use with 8900 only)
3-2850-51-39V	159 001 818	Integral 2850 system, Digital (S ³ L) output, 0.01 cell, PVDF NPT threads
3-2850-51-40V	159 001 819	Integral 2850 system, Digital (S ³ L) output, 0.1 cell, PVDF NPT threads
3-2850-51-41V	159 001 820	Integral 2850 system, Digital (S ³ L) output, 1.0 cell, PVDF NPT threads
3-2850-51-42V	159 001 821	Integral 2850 system, Digital (S ³ L) output, 10.0 cell, PVDF NPT threads
3-2850-51-39VD	159 001 822	Integral 2850 system, Digital (S ³ L) output, 0.01 cell, PVDF ISO threads
3-2850-51-40VD	159 001 823	Integral 2850 system, Digital (S ³ L) output, 0.1 cell, PVDF ISO threads
3-2850-51-41VD	159 001 824	Integral 2850 system, Digital (S ³ L) output, 1.0 cell, PVDF ISO threads
3-2850-51-42VD	159 001 825	Integral 2850 system, Digital (S ³ L) output, 10.0 cell, PVDF ISO threads
3-2850-52-39V	159 001 826	Integral 2850 system, 4 to 20 mA output, 0.01 cell, PVDF NPT threads
3-2850-52-40V	159 001 827	Integral 2850 system, 4 to 20 mA output, 0.1 cell, PVDF NPT threads
3-2850-52-41V	159 001 828	Integral 2850 system, 4 to 20 mA output, 1.0 cell, PVDF NPT threads
3-2850-52-42V	159 001 829	Integral 2850 system, 4 to 20 mA output, 10.0 cell, PVDF NPT threads
3-2850-52-39VD	159 001 830	Integral 2850 system, 4 to 20 mA output, 0.01 cell, PVDF ISO threads
3-2850-52-40VD	159 001 831	Integral 2850 system, 4 to 20 mA output, 0.1 cell, PVDF ISO threads
3-2850-52-41VD	159 001 832	Integral 2850 system, 4 to 20 mA output, 1.0 cell, PVDF ISO threads
3-2850-52-42VD	159 001 833	Integral 2850 system, 4 to 20 mA output, 10.0 cell, PVDF ISO threads

Parts and Accessories

3-9000.392-1	159 000 839	Liquid-tight connector kit, 1 set, ½ in. NPT
3-9000.392-2	159 000 841	Liquid-tight connector kit, 1 set, PG 13.5
3-2850.101-1	159 001 392	Plug-in NIST-traceable recertification tool, 1.0 µS
3-2850.101-2	159 001 393	Plug-in NIST-traceable recertification tool, 2.5 µS
3-2850.101-3	159 001 394	Plug-in NIST-traceable recertification tool, 10.0 µS
3-2850.101-4	159 001 395	Plug-in NIST-traceable recertification tool, 18.2 MΩ
3-2850.101-5	159 001 396	Plug-in NIST-traceable recertification tool, 10.0 MΩ



Georg Fischer Signet LLC, 3401 Aero Jet Avenue, El Monte, CA 91731-2882 U.S.A. • Tel. (626) 571-2770 • Fax (626) 573-2057
For Worldwide Sales and Service, visit our website: www.gfsignet.com • Or call (in the U.S.): (800) 854-4090
For the most up-to-date information, please refer to our website at www.gfsignet.com