

FIGURE 1

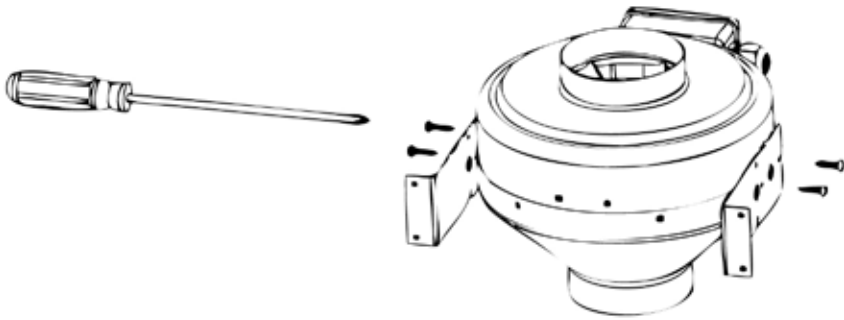
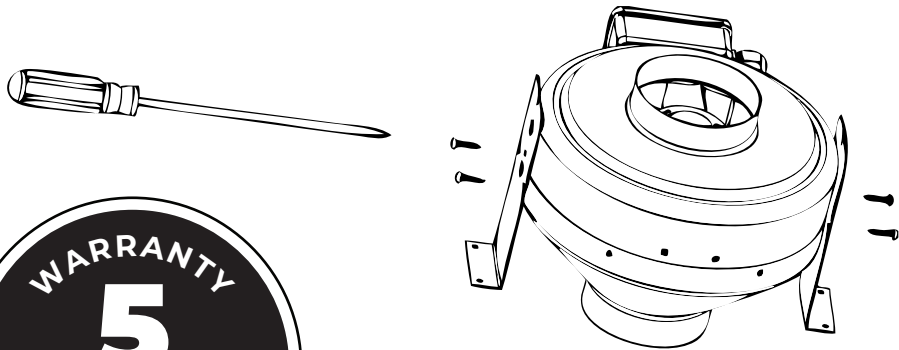

FIGURE 2



COMMON CULTURE

IN-LINE DUCT FANS



COMMON CULTURE

READ AND SAVE THESE INSTRUCTIONS

CAUTION: Before carrying out any maintenance or servicing, ensure the unit is disconnected from the main supply. FOR GENERAL VENTILATION USE ONLY. DO NOT USE TO EXHAUST HAZARDOUS OR EXPLOSIVE VAPORS.

WARNING – TO REDUCE THE RISK OF FIRE, ELECTRICAL SHOCK, OR INJURY TO PERSONS, OBSERVE THE FOLLOWING:

WARNING:

- This fan must be isolated from the power supply during installation and maintenance.
- This fan must be grounded in accordance with local regulations.
- This fan is fitted with a non self-resetting thermal cut out which switches the fan off in the event of a fault condition. To reset, turn the power off for one minute, then back on. Only a qualified and competent person may carry out maintenance after the electrical supply has been isolated.
- TO REDUCE THE RISK OF FIRE, ELECTRICAL SHOCK, OR INJURY, OBSERVE THE FOLLOWING GUIDELINES:
 - a) Use this unit only in the manner intended by the manufacturer. If you have questions, contact the manufacturer or place of purchase.
 - b) Common Culture in-line duct fans are designed for use in up to 95% relative humidity. They are not humidifiers or dehumidifiers. This fan is not suitable for corrosive or explosive atmospheres.
 - c) Before servicing or cleaning the unit, disconnect the fan from the power supply.
 - d) Installation work and electrical wiring must be done by a qualified person(s) in accordance with all applicable codes and standards, including fire-rated construction.
 - e) When cutting or drilling into walls or ceilings, take care not to damage electrical wiring and other hidden utilities.
 - f) Ducted fans should always be vented outside the area occupying the garden for the most efficient operation.
 - g) NEVER allow the unit to directly contact moisture or wet environments.
 - h) Take caution when operating, this unit has an unguarded impeller, therefore DO NOT use it in locations readily accessible to people or animals.

INSTRUCTIONS:

1. Upon purchase, the fan equipment should be visually inspected to check for any damage. Ensure that the impeller has free rotation without scraping or catching on any part of the internal housing.
2. If there are any questions concerning the fan equipment, GrowersHouse or the retailer should be contacted prior to the installation.
3. Use the mounting brackets included with the fan system to securely fasten the unit in the desired mounting position. (Refer to FIGURE 1 & 2 for mounting options)
4. Check the details on the motor rating plate to ensure that the correct power supply (voltage, frequency and phase) is available. An incorrect power supply may lead to permanent damage to the fan motor.
5. Refer to the appropriate wiring diagram, and ensure that all ground connections are made.
6. Means for electrical disconnection must be incorporated in the wiring installation in accordance with the relevant wiring and electrical regulations.

MAINTENANCE:

All Common Culture series in-line duct fans incorporate sealed for life bearings and therefore do not require any lubrication. We would recommend inspection of the product at least once every 12 months to ensure that the motor, impellor, and supporting guards are clean. All fastenings should be checked for tightness and security. In addition, all rotating items should be checked. To inspect the unit, disconnect it from the power supply and any duct work. If debris is evident on the impeller, clean it with a damp (not wet) cloth. DO NOT use any detergents or abrasive materials for cleaning.