

SPECIFICATIONS

Hurricane™ Centrifugal Inline Fan - 10 Inch

Item #736585

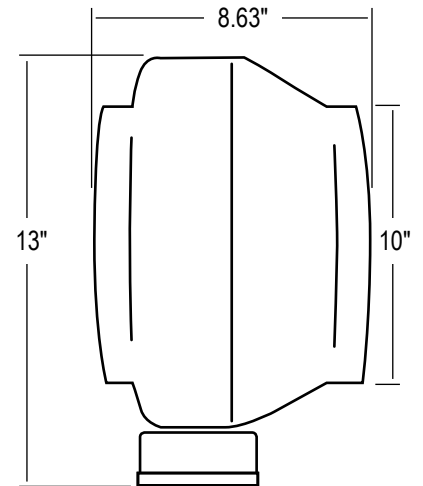

ETL LISTED	Yes
Tested to UL Standard No. 507	
Tested to CSA Standard C22.2 No. 113	
VOLTAGE	120
AMPS	2.1
WATTAGE	236
CFM	780
RPM	2480
POWER CORD	Integrated 8 ft. - 120 Volt
FAN DIAMETER	10 inch
WEIGHT	12 lbs
WARRANTY	5 year

Hurricane™

Hurricane™ Centrifugal Inline Fan - 10 Inch Spec Sheet - Last Updated 04/24/2014

This document is not intended to be used for installation purposes. We cannot cover all specific applications or anticipate all requirements. All specifications are subject to change without notice.