

# SPECIFICATIONS

# Hurricane™ Centrifugal Inline Fan - 12 Inch

Item #736590

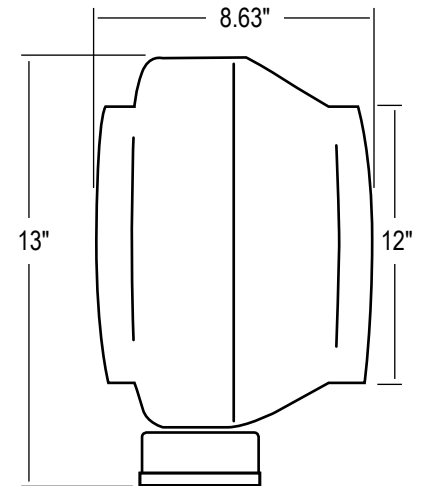

<b>ETL LISTED</b>	Yes
<b>Tested to UL Standard No. 507</b>	
<b>Tested to CSA Standard C22.2 No. 113</b>	
<b>VOLTAGE</b>	120
<b>AMPS</b>	2.5
<b>WATTAGE</b>	300
<b>CFM</b>	1060
<b>RPM</b>	2575
<b>POWER CORD</b>	Integrated 8 ft. - 120 Volt
<b>FAN DIAMETER</b>	12 inch
<b>WEIGHT</b>	16 lbs
<b>WARRANTY</b>	5 year

# Hurricane™

Hurricane™ Centrifugal Inline Fan - 12 Inch Spec Sheet - Last Updated 04242014

*This document is not intended to be used for installation purposes. We cannot cover all specific applications or anticipate all requirements. All specifications are subject to change without notice.*